

2012

# Financial risk management and market performance in restructured electric power markets: Theoretical and agent-based test bed studies

Abhishek Somani  
Iowa State University

Follow this and additional works at: <https://lib.dr.iastate.edu/etd>

 Part of the [Economics Commons](#)

## Recommended Citation

Somani, Abhishek, "Financial risk management and market performance in restructured electric power markets: Theoretical and agent-based test bed studies" (2012). *Graduate Theses and Dissertations*. 12472.  
<https://lib.dr.iastate.edu/etd/12472>

This Dissertation is brought to you for free and open access by the Iowa State University Capstones, Theses and Dissertations at Iowa State University Digital Repository. It has been accepted for inclusion in Graduate Theses and Dissertations by an authorized administrator of Iowa State University Digital Repository. For more information, please contact [digirep@iastate.edu](mailto:digirep@iastate.edu).

**Financial risk management and market performance in restructured electric  
power markets: Theoretical and agent-based test bed studies**

by

Abhishek Somani

A dissertation submitted to the graduate faculty  
in partial fulfillment of the requirements for the degree of  
**DOCTOR OF PHILOSOPHY**

Major: Economics

Program of Study Committee:

Leigh Tesfatsion, Major Professor

James Bushnell

David A. Hennessy

Sergio H. Lence

John Miranowski

Petrutza Caragea

Iowa State University

Ames, Iowa

2012

Copyright © Abhishek Somani, 2012. All rights reserved.

## TABLE OF CONTENTS

<b>LIST OF TABLES</b> . . . . .	v
<b>LIST OF FIGURES</b> . . . . .	vii
<b>ACKNOWLEDGEMENTS</b> . . . . .	ix
<b>CHAPTER 1. Introduction</b> . . . . .	1
1.1 Electricity Markets Restructuring . . . . .	1
1.2 Wholesale Power Markets Overview . . . . .	1
1.3 Original Contributions . . . . .	2
<b>CHAPTER 2. An Agent-Based Test Bed Study of Wholesale Power Market</b>	
<b>Performance Measures</b> . . . . .	4
2.1 Introduction . . . . .	4
2.2 The AMES Test Bed (Version 2.01) . . . . .	8
2.3 Measurement Conundrums for Power Markets . . . . .	13
2.3.1 Detection of Seller Market Power . . . . .	13
2.3.2 Measurement of Market Efficiency . . . . .	14
2.3.3 Attainment of Market Efficiency . . . . .	17
2.4 Market Performance Measures . . . . .	18
2.4.1 Seller Market Power Measures . . . . .	18
2.4.2 Market Efficiency Measure . . . . .	21
2.4.3 ISO Objective Function and Market Efficiency . . . . .	24
2.5 Experimental Design . . . . .	28
2.6 Experimental Findings . . . . .	31
2.7 Calculation of Reported Data Averages and Standard Deviations . . . . .	37

### CHAPTER 3. Financial Risk Management in Electric Restructured Power

<b>Markets: Literature Review</b> . . . . .	41
3.1 Introduction to Restructured Power Markets . . . . .	41
3.2 Electric Power Derivatives . . . . .	42
3.3 Pricing of Electric Power Derivatives . . . . .	43
3.3.1 Electricity versus Other Commodity Pricing . . . . .	43
3.3.2 Electricity Price Patterns . . . . .	43
3.3.3 Pricing Models . . . . .	44
3.3.4 Risk Premium . . . . .	46
3.4 Financial Risk Management in Wholesale Power Markets . . . . .	46
3.5 Risk-Hedging Through Bilateral and FTR Contracts . . . . .	49
3.6 FTR Acquisition Process . . . . .	51
3.6.1 FTR Auction . . . . .	51
3.6.2 FTR Secondary Market . . . . .	52
3.6.3 Grand-fathered FTRs . . . . .	52
3.7 Pricing of Transmission Congestion Derivatives and Partial Risk Hedging . . . . .	53
3.8 FTRs and Market Power . . . . .	55
3.8.1 Impacts of Allocation of FTRs on Market Efficiency . . . . .	56
3.9 FTRs and Transmission Investment . . . . .	57

### CHAPTER 4. Study of Joint Bidding Strategies in Physical and Financial

<b>Electric Power Markets Using Analytical and Agent-Based Models</b> . . . . .	59
4.1 Introduction . . . . .	59
4.2 Dependence of GenCo Bidding Strategy in Day Ahead Market and FTR Auction . . . . .	61
4.2.1 Model Basics . . . . .	62
4.2.2 ISO Day-Ahead Market Optimal Power Flow Problem . . . . .	64
4.2.3 GenCo Day-Ahead Market Supply Choice Problem . . . . .	65
4.2.4 ISO FTR Auction Formulation . . . . .	66
4.2.5 GenCo FTR Choice Problem . . . . .	69
4.3 Three Bus Grid: Analytical Model . . . . .	69

4.3.1	Day $D$ Energy Market . . . . .	69
4.3.2	Day $D - 1$ FTR Auction . . . . .	76
4.4	Three-Bus Grid: Agent Based Model . . . . .	79
4.4.1	Two-Tier Matrix Game Approach . . . . .	80
4.4.2	GenCo Action Set Selection . . . . .	81
4.4.3	Results . . . . .	83
4.5	Conclusion . . . . .	86
<b>CHAPTER 5. Strategic Wind Trading by Firms with Mixed Portfolio of</b>		
	<b>Generation Assets . . . . .</b>	<b>88</b>
5.1	Introduction . . . . .	88
5.2	Restructured Electricity Markets – Overview . . . . .	90
5.2.1	Day-Ahead Energy Market . . . . .	91
5.2.2	Real-Time Energy Market . . . . .	92
5.3	Horizontal Integration and Market Power . . . . .	92
5.3.1	Midwest ISO Market Data . . . . .	93
5.3.2	Incentives for Strategic Wind Power Supply Offers . . . . .	95
5.3.3	Net-Earnings of Firms Reporting Wind Supply Offers Strategically . . . . .	98
5.4	Two-Bus Grid: Analytical Model of Strategic Wind Trading . . . . .	99
5.4.1	Analytical Model Results . . . . .	103
5.5	Two-Bus Grid: Numerical Model of Strategic Wind Trading . . . . .	105
5.5.1	Mathematical Program with Equilibrium Constraints . . . . .	106
5.5.2	GenCo’s Bi-level Optimization Problem . . . . .	106
5.5.3	Numerical Model Results . . . . .	108
5.6	Conclusion . . . . .	109
<b>CHAPTER 6. General Conclusions . . . . . 111</b>		
<b>APPENDIX A. Optimal Power Flow Calculation . . . . . 113</b>		
<b>BIBLIOGRAPHY . . . . . 120</b>		

## LIST OF TABLES

Table 2.1	Dynamic 5-Bus Test Case: Herfindahl-Hirschman Index (HHI) results for a typical day D for the competitive benchmark case (no GenCo learning) as R varies from R=0.0 (100% fixed demand) to R=1.0 (100% price-sensitive demand) . . . . .	38
Table 2.2	Dynamic 5-Bus Test Case: Average Herfindahl-Hirschman Index (HHI) results with standard deviations on successive days for the learning GenCos case as R varies from R=0.0 (100% fixed demand) to R=1.0 (100% price-sensitive demand) . . . . .	38
Table 2.3	Dynamic 5-Bus Test Case: Lerner Index (LI) results for a typical day D for the competitive benchmark case (no GenCo learning) as R varies from R=0.0 (100% fixed demand) to R=1.0 (100% price-sensitive demand)	38
Table 2.4	Dynamic 5-Bus Test Case: Average Lerner Index (LI) results with standard deviations on successive days for the learning GenCos case as R varies from R=0.0 (100% fixed demand) to R=1.0 (100% price-sensitive demand) . . . . .	39
Table 2.5	Dynamic 5-Bus Test Case: Residual Supply Index (RSI) values by hour for the two largest GenCos 3 and 5 during a typical day D for the learning GenCos case as R varies from R=0.0 (100% fixed demand) to R=0.80 (20% fixed demand) . . . . .	39
Table 2.6	Dynamic 5-Bus Test Case: Average Relative Market Advantage Index (RMAI) results with standard deviations on successive days for the learning GenCos case as R varies from R=0.0 (100% fixed demand) to R=1.0 (100% price-sensitive demand) . . . . .	40

Table 2.7	Dynamic 5-Bus Test Case: Average Market Advantage (MA) results with standard deviations on successive days for the learning GenCos case as R varies from R=0.0 (100% fixed demand) to R=1.0 (100% price-sensitive demand) GenCo MAI values . . . . .	40
Table 2.8	Dynamic 5-Bus Test Case: Average Adjusted Operational Efficiency Index (AdjOEI) results with standard deviations on successive days for the learning GenCos case as R varies from R=0.0 (100% fixed demand) to R=1.0 (100% price-sensitive demand) . . . . .	40
Table 4.1	Admissible Exogenous Variables And Functional Forms . . . . .	62
Table 4.2	Endogenous Variables . . . . .	62
Table 5.1	Total Cleared Dispatch by Unit Type for Day-Ahead Market on 11/16/2010	93
Table 5.2	Companies Cleared to Dispatch Both Coal and Wind Energy on 11/16/2010	94
Table 5.3	Description of Variables . . . . .	95
Table 5.4	Extra Net-Earnings from Wind Withholding (dollar) . . . . .	100
Table 5.5	Extra Net-Earnings from Wind Withholding (%) . . . . .	101
Table 5.6	2-Bud Grid for Numerical Model: GenCo Attributes . . . . .	108
Table 5.7	<i>True</i> Wind Supply Offer by Firm with Mixed Portfolio of Generation Assets (MGC) . . . . .	109
Table 5.8	Strategic Wind Trading by Firm with Mixed Portfolio of Generation Assets (MGC) . . . . .	109
Table 5.9	Strategic Wind Trading by Firm with Mixed Portfolio of Generation Assets (MGC) . . . . .	109

## LIST OF FIGURES

Figure 2.1	Energy regions operating under variants of FERC's market design . . .	6
Figure 2.2	AMES test bed architecture . . . . .	8
Figure 2.3	AMES GenCo: A cognitive agent with learning capabilities . . . . .	9
Figure 2.4	AMES GenCos use stochastic reinforcement learning to determine the supply offers they report to the ISO for the day-ahead market. . . . .	11
Figure 2.5	AMES ISO activities during a typical day D . . . . .	12
Figure 2.6	Illustration of AMES dynamics on a typical day D in the absence of system disturbances or shocks for the special case of a 5-bus grid . . .	12
Figure 2.7	Illustration of a competitive equilibrium $(Q^*, P^*) = (5, \$65)$ with corresponding calculations for net buyer and seller surplus. The range of all possible competitive equilibria is given by $Q^*=5$ and $\$60 \leq P^* \leq \$70$ . .	15
Figure 2.8	5-bus transmission grid for the dynamic 5-bus test case . . . . .	28
Figure 2.9	Daily LSE fixed demand (load) profiles for the dynamic 5-bus test case	29
Figure 2.10	Illustration of the construction of the R ratio for measuring relative demand-bid price sensitivity for the special case $R=0.50$ . . . . .	30
Figure 3.1	Illustrative risk management problem for a GenCo operating in a 5-bus wholesale power market under LMP. . . . .	47
Figure 4.1	<i>Rough</i> time-line of restructured wholesale power markets . . . . .	59
Figure 4.2	FTR Auction - Day Ahead Market Feedback Mechanism . . . . .	63
Figure 4.3	Three Node Grid . . . . .	70
Figure 4.4	No Pure Strategy Nash-Supply Function Equilibria . . . . .	73
Figure 4.5	Pure Strategy Nash-Supply Function Equilibria . . . . .	74



Figure 4.6	GenCo 1 Dispatch, Net Earnings, FTR- and Energy-Sales Revenues . . .	77
Figure 4.7	FTR Auction Graphical Solution . . . . .	78
Figure 4.8	Two-Tier Matrix Game Approach for Joint-Optimal Bidding Strategies	82
Figure 4.9	GenCo1 and GenCo2 Action Choices when Thermal Limit on line 1 $\rightarrow$ 3	85
Figure 4.10	GenCo1 and GenCo2 Action Choices when Thermal Limit on line 1 $\rightarrow$ 2	86
Figure 5.1	ISO activities during a typical day D . . . . .	91
Figure 5.2	5- Bus Grid with Wind Plant . . . . .	99
Figure 5.3	Two-bus grid example with mixed generation portfolio company (MGC)	102
A.1	Three Node Grid . . . . .	113
A.2	Branch flows via superposition WITH NO transmission constraints . .	116
A.3	Branch flows for ONE MW power injection at Bus 2 and withdrawn at bus 1 . . . . .	117
A.4	Branch flows via superposition WITH transmission constraints . . . .	118

## ACKNOWLEDGEMENTS

I would like to take this opportunity to express my thanks to those who helped me while conducting research for this thesis.

First and foremost, Dr. Leigh Tesfatsion for her guidance, patience and support throughout this research and the writing of this thesis. Her insights and attention to details have always inspired me, while her words of encouragement kept me on the path of completing the graduate education. My special thanks to her for all that she has done for me over the years.

I would also like to thank my friends and colleagues for their continued support and camaraderie. In particular, I would like to thank Dr. Jerome Dumortier, Dr. Carola Grebitus, Dr. Huan Zhao, Dr. Keith Evans and Dr. Ariel Singerman for providing valuable insights at various times along this journey.

Finally, I will always be indebted to my parents (Vinod and Rita Somani), grandparents (Kishan and Santosh Somani), and brother (Anuj Somani). They have been extremely patient and supportive throughout graduate school and beyond. Dimple (Ishi) Patel, my girlfriend and now wife, has been a rock by my side and has always motivated me to move along at difficult times. I will forever be grateful to my uncle and aunt, Dr. Arun Somani and Manju Somani, for their love and affection. My uncle, through his life-story and work ethics, has always been a source of inspiration.

This thesis research was supported in part by the National Science Foundation under Grant No. 527460 and by grants from the Electric Power Research Center (PRC) of Iowa State University.

## CHAPTER 1. Introduction

### 1.1 Electricity Markets Restructuring

Electric power industries around the world have undergone restructuring - from government regulated to more market oriented. The aim of restructuring the industry has been to reduce monopoly power enjoyed by a few players in the industry and promote more private investment in generation, transmission and distribution facilities leading to greater competition. The US foray into restructuring electricity markets started in the late 1990's, but got off to a disastrous start with the spectacular collapse of California market in the beginning of 2001. Many of the lessons from the episode have been learned and corrected but many issues still remain to be researched.

### 1.2 Wholesale Power Markets Overview

Electric power systems have traditionally been operated as natural monopolies. Restructuring has entailed unbundling of hitherto vertically integrated organizations into independently managed generation, transmission and distribution systems. As a result, electric power markets can be divided into *wholesale* and *retail* layers.

The wholesale power market design proposed by the U.S. Federal Energy Regulatory Commission (FERC) in an April 2003 white paper FERC (2003) encompasses the following core features: central oversight by an *independent system operator* (ISO); a two-settlement system consisting of a day-ahead market supported by a parallel real-time market to ensure continual balancing of electric power supply and demand.

In this new environment, electricity is traded like other commodities in ISO organized power pools. However, power systems must be in instantaneous power balance, i.e. demand must

equal supply at all times. Moreover, at present, electric power cannot be stored economically in substantial amounts. The power flows on transmission systems are governed by physical laws of power flow such as the Kirchoff's law, and are constrained by the overall capacity of transmission lines. During the peak hours of electric power demand, the above mentioned constraints become binding affecting outcomes throughout the grid. Transmission constraints in particular create congestion, which can impede the generation and/or injection of electric power into the grid in "merit-order", i.e., from least-cost generator to high-cost generators. Electric power prices can be very volatile and hence, new forms of risk have arisen due to the restructuring.

As part of restructuring, congestion on electricity transmission grids is now handled in many energy regions by means of *locational marginal pricing* (LMP), i.e., the pricing of electric energy in accordance with the location of its injection or withdrawal from the grid. The LMP so calculated at a node  $k$  measures the least cost to supply an additional unit of load at that location from the resources of the system. The difference in LMPs at any two buses is known as *congestion rent*, which is collected by the ISO. In the case of grid congestion, LMPs can vary widely across the grid, which creates price risk for all market participants.

Using existing market design features, this thesis investigates the risk management issues of market participants and overall efficiency of the wholesale power markets. Additionally, I also study the market rules dealing with renewable energy sources.

### 1.3 Original Contributions

The thesis consists of the following chapters. The first chapter is titled *An Agent-Based Test Bed Study of Wholesale Power Market Performance Measures*, and it presents the difficulties in objectively measuring the market power of various market participants owing to the physical characteristics of electricity. Using a wholesale power market test-bed (AMES), we study the efficacy of various traditional, as well as newly proposed measures of market performance in a dynamic setting, with learning agents. An earlier version (Somani and Tesfatsion (2008)) of the work reported in this chapter was published in *IEEE Computational Intelligence Magazine*, in November 2008. The paper was jointly written with Dr Leigh. Tesfatsion.

The second chapter is titled *Financial Risk Management in Electric Power Markets: Literature Review*, and it introduces the concept of *price risk* in restructured power markets. We present a brief scenario illustrating the origin of price risk. We also introduce various measures market participants employ to hedge against those risks. We then provide the definition of Financial Transmission Rights (FTR) and how those can be used along with Bilateral Contracts to fully hedge against price risk. The chapter also presents a survey of research on implications of FTR market design on overall wholesale power market efficiency.

The fourth chapter is titled *Study of Joint Bidding Strategies in Physical and Financial Electric Power Markets Using Analytical and Agent-Based Models*, and it presents a study of joint bidding strategies of market participants in inter-linked financial and physical energy markets. Specifically, we study how generation companies bid into ISO organized FTR auctions based on their expectations of payoffs in the day-ahead energy markets, and the subsequent supply offer strategies in the day-ahead market, in order to maximize joint net-earnings from energy sales and FTR revenues. The results show that pure strategy Nash-supply function equilibria exist only for certain portfolios of FTRs. It is also observed that the strategic behavior of generation units changes dramatically for different congestion patterns in the grid. However, even for a simple setup with two identical generators, it is not easy to solve the problem using purely analytical methods. Hence, we use agent-based computational methods to solve for the joint decision making problem. Generation companies (GenCos) are modeled as adaptive learners in both the markets, interacting repeatedly with other GenCos until they converge to “stable” action choices in the two markets. The results show that the GenCos are able to learn optimal strategies, based on their spatial location on the grid. Additionally, the GenCos can systematically coordinate their strategies in the two markets.

The fifth chapter is titled *Strategic Wind Trading by Firms with Mixed Portfolio of Generation Assets*, and it presents the strategic incentives of companies with both conventional units and wind plants, to under/over-report wind supply offers in day-ahead markets, relative to the expected wind power output in real-times markets. The use of analytical and numerical methods demonstrates the strategic incentives of mixed generation portfolio companies.

## CHAPTER 2. An Agent-Based Test Bed Study of Wholesale Power Market Performance Measures

Wholesale power markets operating over transmission grids subject to congestion have distinctive features that complicate the detection of market power and operational inefficiency. This study uses a wholesale power market test bed with strategically learning traders to experimentally test the extent to which market performance measures commonly used for other industries are informative for the dynamic operation of restructured wholesale power markets. Examined measures include the Herfindahl-Hirschman Index (HHI), the Lerner Index (LI), the Residual Supply Index (RSI), the Relative Market Advantage Index (RMAI), and the Operational Efficiency Index (OEI).

### 2.1 Introduction

The U.S. electric power industry is currently undergoing substantial changes in both its structure (ownership and technology aspects) and its architecture (operational and oversight aspects). These changes involve attempts to move the industry away from highly regulated markets with administered cost-based pricing and towards competitive markets in which prices more fully reflect supply and demand forces.

The goal of these changes is to provide industry participants with better incentives to control costs and introduce innovations. The process of enacting and implementing policies and laws to bring about these changes has come to be known as *restructuring*.

This restructuring process has been controversial. The meltdown in the restructured California wholesale power market in the summer of 2000 has shown what can happen when market mechanisms with poorly designed incentive structures are implemented without proper testing.

Following the California crisis, many energy researchers have eloquently argued the need to combine sound physical understanding of electric power and transmission grid operation with economic analysis of incentives in order to develop electricity markets with good real-world performance characteristics.

Many commercially available packages for power system analysis now incorporate components critical for the simulation of restructured electricity markets (e.g. optimal power flow solvers). However, these packages have three major drawbacks.

First, the critical effect of incentives on human participant behaviors is typically not addressed. Second, the proprietary nature of these packages generally prevents users from gaining a complete and accurate understanding of what has been implemented, restricts the ability of users to experiment with new software features, and hinders users from tailoring software to specific needs. Third, the concern for commercial applicability to large-scale real-world systems makes these packages cumbersome to use for research, teaching, and training purposes requiring intensive experimentation and sensitivity analyses.

In response to these concerns, a group of researchers at Iowa State University has been working to develop the AMES Wholesale Power Market Test Bed.<sup>1</sup> AMES is an agent-based computational laboratory suitable for studying the dynamic performance of restructured wholesale power markets in a manner that addresses both economic and engineering concerns. A key aspect of the AMES project is the release of AMES as open-source software to encourage interdisciplinary communication and cumulative enhancements.

AMES incorporates core elements of a wholesale power market design recommended by the U.S. Federal Energy Regulatory Commission in an April 2003 White Paper FERC (2003). This design recommends the operation of wholesale power markets by Independent System Operators (ISOs) or Regional Transmission Organizations (RTOs) using *locational marginal prices (LMPs)* to price energy by the location of its injection into or withdrawal from the transmission grid.

---

<sup>1</sup>Detailed descriptions of AMES can be found in refs. (Sun and Tesfatsion (2007b,a); Li et al. (2008a,b)). AMES is an acronym for *Agent-based Modeling of Electricity Systems*. The first version of AMES was released as an open-source Java software package at the IEEE PES General Meeting in June 2007. Downloads, manuals, and tutorial information for all AMES version releases to date can be accessed at AME ([http://www.ames.iastate.edu](#)).



Figure 2.1 Energy regions operating under variants of FERC's market design

As shown in Fig. 2.1, variants of FERC's proposed wholesale power market design have now been adopted in many regions of the U.S. These regions include New England (ISO-NE), New York (NYISO), the mid-atlantic states (PJM), the midwest (MISO), the southwest (SPP), and California (CAISO). According to Joskow (2006), over 50% of generating capacity in the U.S. is now operating under some variant of FERC's market design.

AMES models electric power sellers (generation companies) with learning capabilities interacting over time with electric power buyers (load-serving entities) in an ISO-managed wholesale power market. This market operates over an AC transmission grid subject to congestion. The ISO manages congestion on the grid by means of LMPs derived from optimal power flow solutions.

This study explores the potential usefulness of test beds such as AMES for practical energy policy concerns. Specifically, we use AMES to experimentally test the extent to which market performance measures commonly used for other industries are informative for the dynamic operation of restructured wholesale power markets.



In particular, we focus on the measurement of “seller market power” and “market efficiency” relative to a “competitive equilibrium ” benchmark. *Competitive equilibrium* is said to hold for a market when all traders take prices as given in the formulation of their demands and supplies, and the market price is then set to equate total market demand to total market supply. *Seller market power* refers to the ability of a seller to profitably raise the market price of a good relative to competitive equilibrium conditions. *Market efficiency* measures the degree to which the total net surplus (value) secured by sellers and buyers through actual market operations matches the maximum total net surplus that sellers and buyers would secure under competitive equilibrium conditions.

The organization of this study is as follows. The main features of the AMES test bed are outlined in Section 2.2. In Section 2.3 we elaborate on several special factors complicating the detection and prevention of seller market power and the measurement and attainment of market efficiency in restructured wholesale power markets. In particular, we show that the standard ISO optimal power flow objective function used to manage these markets deviates systematically from the standard economic measure for market efficiency when grid congestion is present.

In Section 2.4 we provide careful definitions for the specific seller market power and market efficiency measures to be experimentally examined in this study. We start with two commonly used measures for seller market power, the *Herfindahl-Hirschman Index (HHI)* and the *Lerner Index (LI)*. We then present the *Residual Supply Index (RSI)* recently developed by CAISO researchers as a test for seller market power in wholesale power markets. We next explain the *Relative Market Advantage Index (RMAI)*, a market performance measure developed by Nicolaisen et al. (2001) as a necessary condition for seller market power. Finally, we examine a measure for efficient market operations referred to as the *Operational Efficiency Index (OEI)*.

Section 2.5 sets out a simple experimental design permitting comparisons of the strengths and weaknesses of each of these measures relative to its intended purpose. Section 2.6 presents some of our main experimental findings to date.

- **Traders**
  - LSEs (bulk-power buyers)
  - GenCos (bulk-power sellers with learning capabilities)
- **Independent System Operator (ISO)**
  - Day-ahead hourly scheduling via bid/offer-based DC optimal power flow (OPF)
  - System reliability assessments
- **Two-settlement process**
  - Day-ahead market (double auction, financial contracts)
  - Real-time market (settlement of differences)
- **AC transmission grid**
  - LSEs and GenCos located at user-specified busses across the transmission grid
  - Congestion managed via locational marginal pricing

Figure 2.2 AMES test bed architecture

## 2.2 The AMES Test Bed (Version 2.01)

AMES(V2.01) incorporates, in simplified form, core features of the wholesale power market design proposed by the U.S. FERC (2003); see Fig. 2.2. A detailed description of these features can be found in materials provided at the AME () homepage.

Below is a summary description of the logical flow of events in the AMES(V2.0) wholesale power market:

- The AMES wholesale power market operates over an *AC transmission grid* starting on day 1 and continuing through a user-specified maximum day (unless terminated earlier in accordance with a user-specified stopping rule). Each day D consists of 24 successive hours  $H = 00,01, \dots,23$ .
- The AMES wholesale power market includes an *Independent System Operator (ISO)* and a collection of energy traders consisting of *Load-Serving Entities (LSEs)* and *Generation Companies (GenCos)* distributed across the busses of the transmission grid. Each of these entities is implemented as a software program encapsulating both methods and data; see, e.g., the schematic depiction of a GenCo in Fig. 2.3

<p><b>Public Access:</b></p> <p>// <b>Public Methods</b>  getWorldEventSchedule(clock time);  getMarketProtocols( supply offer reporting, settlement,...);  getMarketProtocols( ISO market power mitigation);  Methods for receiving data;  Methods for retrieving stored GenCo data.</p>
<p><b>Private Access:</b></p> <p>// <b>Private Methods</b>  Methods for gathering, storing, and sending data;  Methods for calculating my expected/actual net earnings;  Method for updating my supply offers (<b>LEARNING</b>).</p> <p>// <b>Private Data</b>  My grid location, cost function, capacity, current wealth... ;  Historical data (cleared supply offers, LMPs, ...);  Address book (communication links).</p>

Figure 2.3 AMES GenCo: A cognitive agent with learning capabilities

- The objective of the ISO is the reliable attainment of appropriately constrained *operational efficiency* for the wholesale power market, i.e., the maximization of buyer and seller total net earnings (surplus) subject to generation and transmission constraints.
- In an attempt to attain this objective, the ISO undertakes the daily operation of a *day-ahead market* settled by means of *locational marginal pricing (LMP)*, i.e., the determination of prices for electric power in accordance with both the locating and timing of its injection into, or withdrawal from, the transmission grid. Roughly stated, a *locational marginal price* at any particular transmission grid bus is the least cost to the system of servicing demand for one additional megawatt (MW) of electric power at that bus.<sup>2</sup>
- The objective of each LSE is to secure power for its downstream (retail) customers. During the morning of each day D, each LSE reports a demand bid to the ISO for the day-ahead market for day D+1. Each demand bid consists of two parts: a *fixed demand*

<sup>2</sup>In reality, LMPs are shadow prices for “nodal balance constraints” constituting part of the constraint set of optimal power flow problems and are derived as derivatives of the optimized power flow objective function with respect to particular types of perturbations of these constraints. Moreover, these nodal balance constraints are imposed at “pricing nodes” that might not correspond to actual physical bus locations on the grid. For expositional simplicity, throughout this study we use the standard engineering short-hand description for LMPs as valuations for single-unit increases in demand and we treat pricing nodes as coincident with transmission grid busses. For a more rigorous explanation and derivation of LMPs, see Sun and Tesfatsion (2007a).

*bid* (i.e., a 24-hour load profile); and 24 *price-sensitive demand bids* (one for each hour), each consisting of a linear demand function defined over a purchase capacity interval. LSEs have no learning capabilities; LSE demand bids are user-specified at the beginning of each simulation run.

- The objective of each GenCo is to secure for itself the highest possible net earnings each day. During the morning of each day  $D$ , each GenCo  $i$  uses its current action choice probabilities to choose a *supply offer* from its action domain  $AD_i$  to report to the ISO for use in all 24 hours of the day-ahead market for day  $D+1$ .<sup>3</sup> Each supply offer in  $AD_i$  consists of a linear marginal cost function defined over an operating capacity interval. GenCo  $i$ 's ability to vary its choice of a supply offer from its action domain  $AD_i$  permits it to adjust the ordinate/slope of its reported marginal cost function and/or the upper limit of its reported operating capacity interval in an attempt to increase its daily net earnings.
- After receiving demand bids from LSEs and supply offers from GenCos during the morning of day  $D$ , the ISO determines and publicly reports hourly power supply commitments and LMPs for the day-ahead market for day  $D+1$  as the solution to hourly bid/offer-based *DC optimal power flow (DC-OPF)* problems. *Transmission grid congestion* is managed by the inclusion of congestion cost components in LMPs.
- At the end of each day  $D$ , the ISO settles all of the commitments for the day-ahead market for day  $D+1$  on the basis of the LMPs for the day-ahead market for day  $D+1$ .
- At the end of each day  $D$ , each GenCo  $i$  uses *stochastic reinforcement learning* to update the action choice probabilities currently assigned to the supply offers in its action domain  $AD_i$  taking into account its day- $D$  settlement payment ("reward"). In particular, as depicted in Fig. 2.4, if the supply offer reported by GenCo  $i$  on day  $D$  results in a

<sup>3</sup>In the MISO (2008), GenCos each day are actually permitted to report a *separate* supply offer for each hour of the day-ahead market. In order to simplify the learning problem for GenCos, the current version of AMES restricts GenCos to the daily reporting of only one supply offer for the day-ahead market. Interestingly, the latter restriction is imposed on GenCos by the ISO-NE (2008) in its particular implementation of FERC's market design. (Baldick and Hogan, 2002, pp. 18-20) conjecture that imposing such limits on the ability of GenCos to report distinct hourly supply offers could reduce their ability to exercise seller market power.

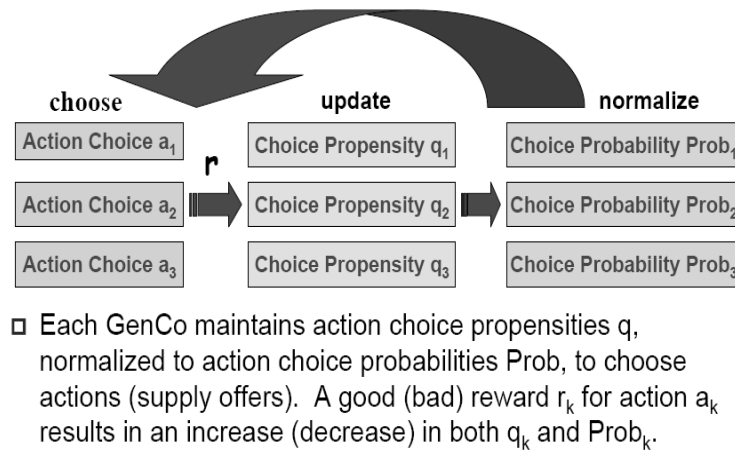

Figure 2.4 AMES GenCos use stochastic reinforcement learning to determine the supply offers they report to the ISO for the day-ahead market.

relatively good reward, GenCo  $i$  increases the probability of choosing this supply offer on day  $D+1$ , and conversely.

- There are no system disturbances (e.g., weather changes) or shocks (e.g., forced generation outages or line outages). Consequently, the binding financial contracts determined in the day-ahead market are carried out as planned and traders have no need to engage in real-time (spot) market trading.
- Each LSE and GenCo has an initial holding of money that changes over time as it accumulates earnings and losses.
- There is no entry of traders into, or exit of traders from, the wholesale power market. LSEs and GenCos are currently allowed to go into debt (negative money holdings) without penalty or forced exit.
- The activities of the ISO on a typical day  $D$  are depicted in Fig. 2.5. The overall dynamical flow of activities in the wholesale power market on a typical day  $D$  in the absence of system disturbances or shocks is depicted in Fig. 2.10.

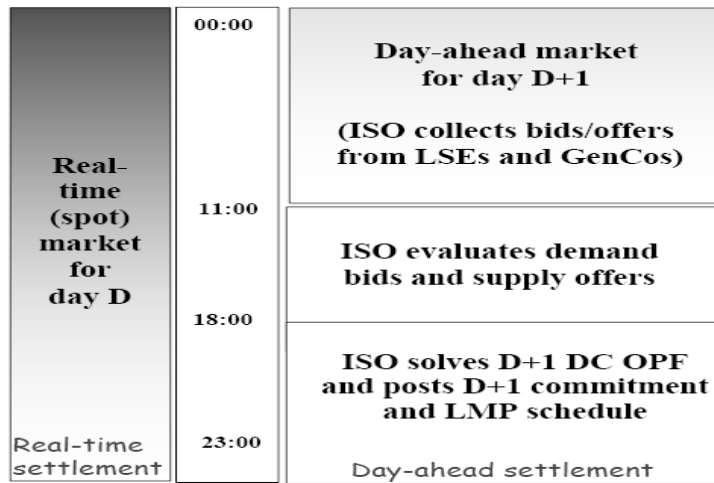

Figure 2.5 AMES ISO activities during a typical day D

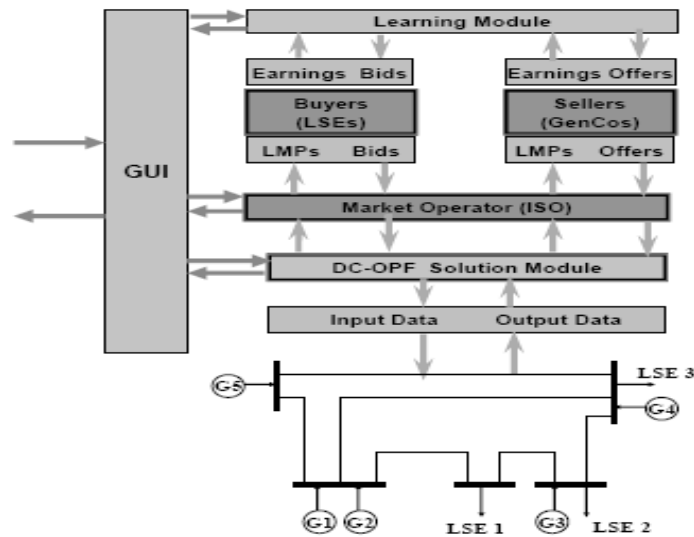

Figure 2.6 Illustration of AMES dynamics on a typical day D in the absence of system disturbances or shocks for the special case of a 5-bus grid

## 2.3 Measurement Conundrums for Power Markets

### 2.3.1 Detection of Seller Market Power

Although the exercise of seller market power in restructured wholesale power markets can have substantial adverse effects on the efficiency, reliability, and fairness of market operations, it is difficult to construct measures for its reliable detection. Excellent discussions elaborating some of the reasons for this can be found in Borenstein et al. (1999), Sheffrin et al. (2004), (Stoft, 2002, Chapter 4), and Twomey et al. (2005). Here we briefly review the key issues.

On the one hand, the complexity of the rules and regulations governing market operations in restructured wholesale power markets creates opportunities for GenCos to game the system to their advantage through strategic behaviors, either individually or in tacit collusion. These strategic behaviors take two main forms: *economic withholding of capacity* through a reporting of higher-than-true marginal costs; and *physical withholding of capacity*.

Economic withholding of capacity can induce higher prices for cleared supply as well as *out-of-merit-order dispatch*, i.e., more expensive generation dispatched in place of less expensive generation. This results in inefficient (and politically important) transfers of wealth away from LSEs and their downstream (retail) consumers and towards GenCos.

Physical withholding of capacity can induce higher prices for the remaining offered capacity and hence higher net earnings for GenCos that withhold only a portion of their capacities. It can also result in out-of-merit-order dispatch. In addition, however, physical withholding of capacity increases the chances of *inadequacy events* in which offered capacity is insufficient to meet total fixed demand, forcing ISOs to take special actions to avoid the breakdown of power flow on the grid.

In short, strategic withholding results in distorted price signals as well as the possible need for special non-market dispatch. This hinders the efficient and fair use of existing resources as well as the proper assessment of future transmission and generation investment needs.

On the other hand, the physical laws governing power flow on transmission grids mean that these grids are strongly connected networks. Injections or withdrawals of power at one location on the grid can have substantial effects on branch flows and bus sensitivities at distant locations.

In particular, if an injection of power at a particular grid location leads to grid congestion, this will cause at least some separation of LMPs across the grid. Indeed, as explained more carefully in Subsection 2.3.2, under congested conditions LMPs can strictly exceed the marginal cost of *every* individual GenCo at the system operating point, despite the complete absence of any deliberate exercise of seller market power.

Alternatively, a change in the *pattern* of grid congestion can cause dramatic discontinuous changes in LMP levels even if the overall number of congested branches remains the same. For example, a *load pocket* can suddenly emerge in which a GenCo effectively becomes a high-priced monopolist with respect to the demand for power in its local area because outside power cannot be transported into this local area. In standard economic terminology, the energy market has segmented into submarkets, and the electric power quantities offered for sale at locations within distinct submarkets now effectively represent distinct goods supporting a distinct array of prices.

Standard economic measures for seller market power have not been designed with these complex effects in mind. Consequently, their usefulness for the detection of seller market power in restructured wholesale power markets is not clear.

### 2.3.2 Measurement of Market Efficiency

The standard economic measurement of “market efficiency” also has to be carefully reconsidered for restructured wholesale power markets. Market efficiency means there are no wasted resources. Wastage can be identified as being of two types: (1) physical wastage, in the sense that some valued units of resource remain unused; and (2) wastage of value, in the sense that some units of resource are not being used by those who value them most.

The efficiency of a market can be measured in terms of the “total net surplus” attained by buyers and sellers. *Net buyer surplus* is defined to be the maximum amount that a buyer would have been willing to pay for a quantity of goods  $q$  *minus* the actual payment that the buyer makes for  $q$ . Similarly, *net seller surplus* is defined to be the payment received by a seller for the sale of a quantity of goods  $q$  *minus* the minimum payment the seller would have been willing to accept in payment for  $q$ . The *total net surplus (TNS)* attained in a market  $M$



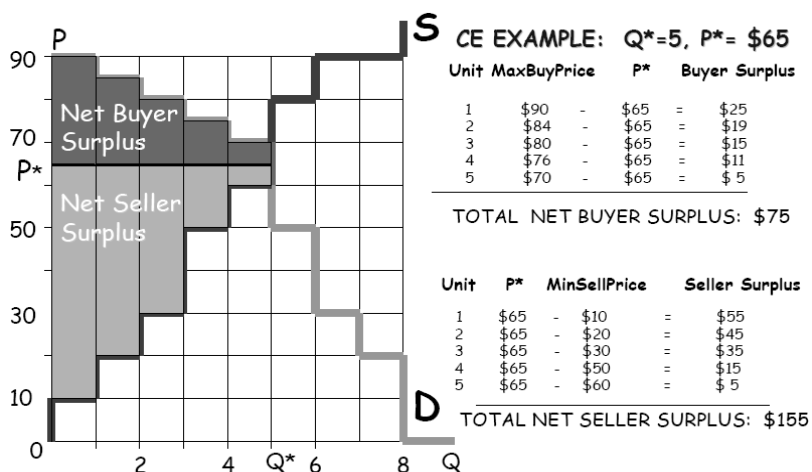

Figure 2.7 Illustration of a competitive equilibrium  $(Q^*, P^*) = (5, \$65)$  with corresponding calculations for net buyer and seller surplus. The range of all possible competitive equilibria is given by  $Q^*=5$  and  $\$60 \leq P^* \leq \$70$ .

during a specified time period  $T$  is then defined to be the sum of the net surplus attained by all buyers and sellers in  $M$  during  $T$ .

*Market efficiency* is said to be achieved in a market if TNS is maximized, since wastage of resources is then minimized. In standard textbook market settings, TNS is maximized in competitive equilibrium, that is, when all buyers and sellers in the market take prices as given in the formulation of their demands and supplies and the market price  $P^*$  equates total market demand to total market supply at some common quantity level  $Q^*$ . The equilibrium quantity  $Q^*$  is the summation of all of the *cleared* quantities  $q_i^*$  supplied by individual sellers  $i$ , that is, the quantities  $q_i^*$  that can be scheduled for purchase because for each successive quantity unit the market price lies between some buyer's maximum willingness to pay and the seller's minimum acceptable price.

See, for example, the depiction of a competitive equilibrium in Fig. 2.7 with accompanying calculations for net buyer and seller surplus. The demand curve  $D$  depicts buyer maximum willingness to pay for each successive unit demanded, in descending order, and the supply curve

S depicts seller minimum acceptable sale price for each successive unit supplied, in ascending order. The eight quantity units offered for sale might all belong to a single seller that is not capacity constrained. Alternatively, the eight units could represent units offered for sale by different capacity-constrained sellers—e.g., eight different sellers, each capacity-constrained to supply at most one unit. In either case only five of these units can be cleared in competitive equilibrium because buyer maximum willingness to pay drops below seller minimum acceptable sale price for any additionally offered quantity units.

Economists typically equate a seller's minimum acceptable sale price with its marginal cost. It is common to test for the maximization of TNS at a point  $(Q', P')$  by testing whether the market price  $P'$  lies between  $MC_-(Q')$  and  $MC_+(Q')$ , the left-hand and right-hand seller marginal costs evaluated at the market output level  $Q'$ .<sup>4</sup> If seller marginal cost is a well-defined continuous function of  $Q$  at  $Q'$ , then left-hand and right-hand seller marginal costs coincide at  $Q'$  and this requirement reduces to the standard condition  $P' = MC(Q')$ .<sup>5</sup> If  $P'$  exceeds right-hand seller marginal cost at  $Q'$ , this raises the possibility that additional buyer/seller surplus could be extracted from the market by the sale of additional quantity units. It also raises the possibility that sellers are exercising market power through the deliberate withholding of capacity.

Due to network externalities, however, this  $P/MC$  test must be applied with great caution in restructured wholesale power markets operating over transmission grids with congestion managed by LMP pricing. To understand why, it is necessary to consider carefully the constructive derivation of LMPs.

As noted in Section 2.2, the LMP at each bus of the transmission grid is defined as a right-hand system marginal cost: namely, the least cost *to the system* of servicing an *additional*

<sup>4</sup>Assuming the seller minimum acceptable sale prices in Fig. 2.7 are marginal costs, the depicted competitive equilibrium  $(Q^*, P^*) = (5, \$65)$  satisfies precisely this type of requirement, as follows:  $\$60 = MC_-(Q^*) < P^* = \$65 < MC_+(Q^*) = \$80$ . A similar requirement can be formulated stating that the market price  $P'$  should lie between the left-hand and right-hand expressions for buyer maximum willingness to pay at  $Q'$ . Both of these requirements follow from the following alternative geometrically-expressed form for the definition of competitive equilibrium in standard market contexts: A technologically feasible quantity-price combination  $(Q', P')$  is a competitive equilibrium if and only if it is an intersection point of the market demand and supply curves with all vertical and horizontal portions included.

<sup>5</sup>Marginal cost curves for power markets typically have jump points due to generation capacity constraints. See (Stoft, 2002, Chapter 1-6) for a careful discussion of marginal cost calculations for power markets.

megawatt (MW) of electric power demand at that bus. By definition, then, each LMP is determined only by the *marginal* GenCos at the system operating point, i.e., by the GenCos that are capable of supplying additional demand because they are currently operating strictly below their upper capacity limits.

Consequently, as is well understood, the LMP received by each individual *non-marginal* (i.e., capacity-constrained) GenCo for each MW it sells at its operating point can strictly exceed its *left-hand* marginal cost.<sup>6</sup> The MWs supplied by these non-marginal GenCos constitute “inframarginal” quantity units in the terminology of standard microeconomic theory, similar to the quantity units to the left of  $Q^*=5$  in Fig. 2.7.

What is not as well understood, however, is that an LMP can strictly exceed the *right-hand* marginal cost of each *marginal* GenCo if grid congestion requires out-of-merit-order dispatch. For example, to service an additional MW of demand at some bus  $k$  for some hour  $H$  in the presence of grid congestion might require that less expensive generation at some second bus  $k'$  be backed down, e.g., by 2MWs at \$20/MWh, and that more expensive generation at some third bus  $k''$  be brought up, e.g., by 3MWs at \$30/MWh, in order to avoid overloading an already constrained transmission grid branch. In this case the *system* marginal cost of servicing an additional MW of demand at bus  $k$  for hour  $H$ —i.e., the LMP at bus  $k$  for hour  $H$ —is  $\$50/h = [3\text{MWs} \cdot (\$30/\text{MWh}) - 2\text{MWs} \cdot (\$20/\text{MWh})]$ . If the 3MWs at \$30/MWh are supplied by a GenCo that has even more operating capacity available at a marginal cost not exceeding \$49/MWh, then the LMP at bus  $k$  strictly exceeds the right-hand marginal cost of this marginal GenCo.

### 2.3.3 Attainment of Market Efficiency

Subsection 2.3.2 discusses a number of issues that seriously complicate the measurement of market efficiency for day-ahead markets in restructured wholesale power markets. However, a potentially more fundamental problem is that the form of the objective function used by ISOs in these markets to determine LMPs and power commitments renders problematic the *attainment* of market efficiency.

<sup>6</sup>The marginal cost curve of a capacity-constrained GenCo goes vertical at its upper capacity limit, implying that the *right-hand* marginal cost of a GenCo operating at its upper capacity limit is effectively infinite.

This issue is extremely important but fairly technical to explain. For this reason we delay discussion of this issue until subsection 2.4.3, below, so that we can exploit the previous development of a quantitative measure for market efficiency specifically tailored for wholesale power markets.

## 2.4 Market Performance Measures

### 2.4.1 Seller Market Power Measures

*Market concentration* is the extent to which a relatively large share of market activity is carried out by a relatively small number of participant firms. Market concentration is routinely used as an indicator of potential seller market power by the U.S. Department of Justice in antitrust actions as well as by researchers in academic studies. The intuitive idea is that anticompetitive behavior by firms is to be expected in a market that is highly concentrated.

Market concentration measures are most often applied to the seller side of a market. Typically these measures depend critically on two structural attributes: (a) the number of firms selling into a market; and (b) the relative “market share” of these seller firms as measured either by output, by operating capacity, or by sales revenues. All else equal, these measures indicate an increase in concentration either when the number of firms decreases or when the market share of the largest firms increases. A key unresolved issue in the construction of such measures is the relative weight that should be attached to the two structural dimensions (a) and (b).

One of the most commonly used market concentration measures is as follows:

- **The Herfindahl-Hirschman Index (HHI):**

Let  $s_n$  denote the percentage share of market output of the  $n$ th largest firm in a market with  $N$  firms for some time period  $T$ . Then

$$\text{HHI} = \sum_{n=1}^N s_n^2 \quad (2.1)$$

Note that market share in (2.1) is defined as the percentage share of market *output*. Consequently, the corresponding HHI is an *ex post* measure in the sense it depends on actual market outcomes.

Larger values for HHI indicate a higher degree of concentration and hence a higher potential for the exercise of seller market power. For example, if a market consists of just one firm, then the percentage share of market output for this one firm will be 100% and HHI will equal 10,000 ( $100^2$ ). Conversely, if a market consists of a large number of small firms, the percentage share of market output for each of these small firms will be close to 0%, implying that HHI will have a value close to 0. However, the HHI has well known deficiencies as an indicator of seller market power in any market. For example, it focuses only on the the supply side of a market, ignoring demand conditions, and it ignores differences in firm costs and the potential entry of rival firms; see (Pepall et al., 1999, Section 2.1).

One of the most commonly used direct measures for seller market power is the “Lerner Index,” defined as follows:<sup>7</sup>

- **Lerner Index (LI):**

For any firm  $i$  supplying a positive quantity  $q$  at a per-unit sale price  $P$  in some time period  $T$ ,

$$LI(i) = \left[ \frac{P - MC_i(q)}{P} \right], \quad (2.2)$$

where  $MC_i(q)$  denotes firm  $i$ 's true left-hand marginal cost, evaluated at  $q$ .

The LI builds on the idea, explained and critiqued in Subsection 2.3, that positive discrepancies between market price and seller marginal cost indicate the possible exercise of seller market power through the withholding of capacity.

For later purposes, we now specialize definition (2.2) to wholesale power markets operating under LMP pricing. Consider a GenCo  $i$  located at a bus  $k(i)$  in day  $D$ . Let  $p_{Gi}$  denote the total amount of electric power that GenCo  $i$  is cleared to sell in the day-ahead market for

<sup>7</sup>The definition of the Lerner Index is typically presented without distinguishing between left-hand and right-hand marginal cost, important for the consideration of capacity-constrained firms; see, e.g., Stoft (Stoft, 2002, p. 339). In empirical applications, however, the “marginal costs” appearing in Lerner Index calculations appear universally to be left-hand (historically realized) marginal costs. Consequently, we state the definition in this form.

hour  $H$  of day  $D+1$ . Also, let  $LMP_{k(i)}$  denote the LMP at bus  $k(i)$  in hour  $H$  of day  $D+1$ . By definition,  $LMP_{k(i)}$  is the sale price that GenCo  $i$  is scheduled to receive for each MW of its cleared supply  $p_{Gi}$ . Finally, let  $MC_i(p_{Gi})$  denote GenCo  $i$ 's true left-hand marginal cost, evaluated at  $p_{Gi}$ . Then

$$LI(i) = \left[ \frac{LMP_{k(i)} - MC_i(p_{Gi})}{LMP_{k(i)}} \right] \quad (2.3)$$

We next present a measure that considers both the demand and supply sides of a market by building on the concept of a ‘‘pivotal supplier.’’ A firm  $i$  participating in some market  $M$  is called a *pivotal supplier* if total operating capacity in  $M$  *without* the capacity of firm  $i$  is not sufficient to meet market demand.

Although relevant for any market, the concept of a pivotal supplier has special salience for restructured wholesale power markets for which much of the bid-in demand is *fixed*, i.e., not sensitive to price.<sup>8</sup> More precisely, electric power effectively cannot be stored, and imbalances between demand and supply of electric power on a grid lead to voltage instabilities and ultimate grid collapse if not swiftly corrected. For these reasons, ISOs in wholesale power markets must ensure at all times that generation capacity is sufficient to meet total fixed demand. This requirement means that GenCos in restructured wholesale power markets who are pivotal suppliers for total fixed demand have tremendous potential to exercise seller market power through the withholding of their capacity.

The following ‘‘Residual Supply Index’’ tests for the pivotal-supplier status of arbitrary groupings of firms participating in a market.

- **Residual Supply Index (RSI):**

Let  $N$  denote the collection of all firms participating in a market during some time period  $T$ . For any subset  $S$  of  $N$ , let  $TotalCap(S)$  denote the total operating capacity of the firms in  $S$  during  $T$ . Also, let  $TotalDemand$  denote total demand during  $T$ . Then

$$RSI(S) = \left[ \frac{TotalCap(N) - TotalCap(S)}{TotalDemand} \right] \quad (2.4)$$

<sup>8</sup>For example, in the U.S. Midwest Independent System Operator (MISO), LSEs are permitted to submit demand bids to the ISO for the day-ahead market that have both both price-sensitive and fixed parts. However, according to demand bid data released by the MISO MISO (2008), at the present time only about 1% of the total bid-in demand for the day-ahead market is price sensitive.

If  $RSI(S) < 1$ , the indication is that the firms in  $S$  have potential seller market power because total demand cannot be met without their capacity. When total demand and firm capacities are known in advance, the RSI represents an *ex ante* measure in the sense that it can be calculated in advance of actual market outcomes.

The RSI in various forms was first proposed by a group of researchers affiliated with the Department of Market Analysis at the California Independent System Operator (CAISO). See (Sheffrin et al., 2004, p. 60) for a report on empirical findings for these measures applied to CAISO market data. See, also, Mani and Ainspan (2005) for applications of RSI(1) to the New England wholesale power market (ISO-NE).

Finally, we present the definition of a market performance measure proposed in Nicolaisen et al. (2001) as a necessary indicator of market power for either a buyer or seller. Here we specialize the measure to a seller.

- **Relative Market Advantage Index (RMAI):**

Let  $\text{NetEarn}^C(i)$  denote the net earnings that a seller  $i$  would earn in competitive equilibrium during some time period  $T$ , and let  $\text{NetEarn}^A(i)$  denote the net earnings of seller  $i$  in actual market trading during  $T$ . Assuming  $\text{NetEarn}^C(i)$  is not zero,

$$\text{RMAI}(i) = \left[ \frac{\text{NetEarn}^A(i) - \text{NetEarn}^C(i)}{\text{NetEarn}^C(i)} \right] \quad (2.5)$$

In order for seller  $i$  to have profitably exerted control over the market price during  $T$ ,  $\text{RMAI}(i)$  must necessarily be positively valued. Consequently,  $\text{RMAI}(i) > 0$  is a necessary condition for seller  $i$  to have exercised seller market power during  $T$ .

#### 2.4.2 Market Efficiency Measure

Recall from Subsection 2.3.2 that market efficiency is said to hold for a market if maximum extraction of total net surplus (TNS) is achieved. Moreover, for standard market contexts such as depicted in Fig. 2.7, maximum TNS extraction is achieved in any competitive equilibrium.

Let  $M$  denote a standard market context in some time period  $T$ . Let  $\text{TNS}^C$  denote the (maximum) TNS that could be extracted in market  $M$  in period  $T$  in competitive equilibrium,

and let  $TNS^A$  denote the TNS actually extracted in market M during T. Assuming  $TNS^C$  is positively valued, an “Operational Efficiency Index” can be defined for market M during T as follows:

- **Operational Efficiency Index (OEI):**

$$OEI = \frac{TNS^A}{TNS^C} \quad (2.6)$$

If buyers never purchase goods above their maximum willingness to pay and sellers never sell goods below their minimum acceptable sale price, OEI ranges between 0 and 1 in value with OEI=1 corresponding to 100% market efficiency.

For later purposes, we now specialize the definitions of net buyer surplus, net seller surplus, total net surplus, and OEI to markets for electric power. In particular, we consider the case of  $J$  LSEs and  $I$  GenCos participating in an ISO-managed day-ahead wholesale power market operating under LMP pricing.

In standard economic terminology, an LSE that has a positive fixed (price-insensitive) demand for electric power has a vertical demand curve for these quantity units, implying an infinite maximum willingness to pay for them. If this fixed demand must be met under all circumstances, as is true in ISO-managed day-ahead markets, then the LSE obtains the same infinite benefit from its fixed demand independently of any other market circumstances. Consequently, this benefit does not help to distinguish between the efficiency of different market scenarios because in effect it cancels out when the benefits arising under any two market scenarios are differenced.

For this reason, power economists routinely omit consideration of LSE fixed demand benefits in the construction of measures designed to evaluate relative market efficiency. A special case of this is when all LSE demand is fixed and attention is focused solely on minimization of the total variable costs incurred in satisfying this fixed demand. Here we consider the more general case, reflective of many actual ISO-managed day-ahead wholesale power markets, in which LSE demand bids consist of both both fixed and price-sensitive parts.

Consider an LSE  $j$  located at a transmission grid bus  $k(j)$  in some day D. Let  $p_{Lj}^S$  and  $p_{Lj}^F$  denote the quantities of electric power that LSE  $j$  is cleared to buy in the day-ahead market



for hour H of day D+1 corresponding to its price-sensitive demand-bid function  $D_j(p)$  and its fixed demand bid, respectively. LSE  $j$ 's total cleared demand is thus given by

$$p_{Lj} = [p_{Lj}^S + p_{Lj}^F] \quad (2.7)$$

Also, let  $LMP_{k(j)}$  denote the LMP for bus  $k(j)$  in hour H of day D+1.  $LMP_{k(j)}$  is the price that LSE  $j$  is committed to pay for each MW of its total cleared demand (2.7).

The net buyer surplus of LSE  $j$  corresponding to its total cleared demand (2.7), adjusted to omit the infinitely-valued benefit corresponding to its fixed demand, takes the following form:

$$AdjNBS_{Lj} = \int_0^{p_{Lj}^S} [D_j(p)] dp - LMP_{k(j)} \cdot p_{Lj} \quad (2.8)$$

In (2.8),  $D_j(p)$  denotes LSE  $j$ 's maximum willingness to pay for an increment  $dp$  of power, evaluated at the power level  $p$ . Consequently, the integral term measures the benefit gained by LSE  $j$  from the price-sensitive portion  $p_{Lj}^S$  of its total cleared demand  $p_{Lj}$ , whereas the far-right term denotes the cost to LSE  $j$  for its total cleared demand  $p_{Lj}$ .

Next consider a GenCo  $i$  located at a transmission grid bus  $k(i)$  in some day D. Let  $p_{Gi}$  denote the quantity of electric power that GenCo  $i$  is cleared to sell in the day-ahead market for hour H of day D+1. Also, let  $LMP_{k(i)}$  denote the LMP for bus  $k(i)$  in hour H of day D+1.  $LMP_{k(i)}$  is the price that GenCo  $i$  is committed to accept in payment for each MW of its cleared supply  $p_{Gi}$ .

The net seller surplus of GenCo  $i$  corresponding to its cleared supply  $p_{Gi}$  is therefore given by

$$NSS_{Gi} = LMP_{k(i)} \cdot p_{Gi} - \int_0^{p_{Gi}} [MC_i(p)] dp \quad (2.9)$$

In (2.9),  $MC_i(p)$  denotes GenCo  $i$ 's true left-hand marginal cost (minimum acceptable sale price) for an increment  $dp$  of power, evaluated at the power level  $p$ . Consequently, the integral term measures the true variable cost incurred by GenCo  $i$  for its cleared supply  $p_{Gi}$ , whereas  $LMP_{k(i)} \cdot p_{Gi}$  measures the payments received by GenCo  $i$  for this cleared supply.

The total net surplus attained in the day-ahead market in hour H of day D+1, adjusted by omission of the infinite benefit corresponding to LSE fixed demand, thus takes the following

form:

$$AdjTNS = \sum_{j=1}^J AdjNBS_{Lj} + \sum_{i=1}^I NSS_{Gi} \quad (2.10)$$

We consider two different calculations of AdjTNS:

- AdjTNS<sup>C</sup>: AdjTNS calculated under *competitive benchmark* conditions in which the ISO knows the true structural attributes of all LSEs and GenCos;
- AdjTNS<sup>R</sup>: AdjTNS calculated under auction conditions in which the ISO must depend on the reported demand bids and supply offers of potentially strategic LSEs and/or GenCos with learning capabilities.

In parallel with (2.6), we then define an “adjusted” operational efficiency index as follows:

$$AdjOEI = \frac{AdjTNS^R}{AdjTNS^C} \quad (2.11)$$

The Adjusted OEI (2.11) does not have as straightforward an interpretation as the standardly defined OEI (2.6). For example, AdjTNS calculated under either competitive or auction conditions can be negatively valued in the presence of LSE fixed demands since LSE fixed demand payments are included but LSE fixed demand benefits are not. Moreover, as elaborated in the following section, the standardly assumed ISO objective function for the day-ahead market does not guarantee that AdjTNS<sup>C</sup> equals maximum possible AdjTNS. These issues will be further addressed in Section 2.6, where we present experimental findings for AdjOEI.

### 2.4.3 ISO Objective Function and Market Efficiency

It is typically assumed that an appropriate market objective for policy makers is market efficiency interpreted to mean the maximization of the sum of net buyer and seller surplus, i.e., total net surplus (TNS). As depicted in Fig. 2.7, TNS in standard market contexts can be expressed as the area between the market demand curve and the market supply curve, and maximum TNS is achieved where these curves intersect.

The basic objective typically assumed for ISOs in day-ahead markets is the constrained maximization of the area between the market price-sensitive demand curve and the market supply curve as constructed from the reported price-sensitive demand bids and supply offers

of the participant traders.<sup>9</sup> It is commonly believed that the constrained maximization of this ISO objective function is equivalent to the constrained maximization of adjusted TNS as constructed in (2.10) and hence comports well with standard economic policy prescriptions for the achievement of market efficiency. See, for example, (Cramton et al., 2005, Appendix 1.3, pp. 42-44). However, it will now be shown that this is not necessarily the case.

Consider, for example, an ISO-managed wholesale power market consisting of  $J$  LSEs and  $I$  GenCos. Let the objective function of the ISO in day D for hour H of the day-ahead market in day D+1 be expressed as follows:

$$B^R - C^R = \sum_{j=1}^J \int_0^{p_{Lj}^S} [D_j^R(p)] dp - \sum_{i=1}^I \int_0^{p_{Gi}} [MC_i^R(p)] dp \quad (2.12)$$

In 2.12,  $D_j^R(p)$  denotes LSE  $j$ 's reported price-sensitive demand function, hence the corresponding summed integral expression  $B^R$  denotes the reported total benefits to LSEs corresponding to their reported price-sensitive demand bids (i.e., the area under their reported price-sensitive demand functions up to their cleared demands).  $MC_i^R(p)$  denotes GenCo  $i$ 's reported marginal cost function, hence the corresponding summed integral expression  $C^R$  denotes the reported total variable costs incurred by GenCos (i.e., the area under their reported marginal cost curves up to their cleared supplies).

The question is whether the objective function (2.12) is equivalent to AdjTNS as constructed in (2.10). To see why this is not true in general, consider the following. The payments from LSEs and to GenCos for the day-ahead market in day D+1 are settled through the ISO at the end of day D. Let *ISONetSurplus* denote the net payments collected by the ISO in the day-D settlement for hour H of the day-ahead market in day D+1. Using previously introduced terminology, *ISONetSurplus* can be expressed as follows:

$$\left[ \sum_{j=1}^J LMP_{k(j)} \cdot p_{Lj} - \sum_{i=1}^I LMP_{k(i)} \cdot p_{Gi} \right] \quad (2.13)$$

Combining (2.8), (2.9), (2.10), (2.12), and (2.13), it is seen that

$$B^R - C^R = [AdjTNS^R + ISONetSurplus] , \quad (2.14)$$

<sup>9</sup>Sometimes additional "unit commitment" costs are also included, such as no-load and start-up costs, but this does not affect the essential point of this section.

where  $\text{AdjTNS}^R$  denotes AdjTNS based on *reported* demand bids and supply offers.

Clearly the maximization of (2.14) subject to generation and transmission constraints will not typically ensure the maximization of AdjTNS subject to these same constraints. It might be argued that the inclusion of ISO net surplus in (2.14) along with net buyer and seller surplus is appropriate, since ISOs are also market participants. However, ISOs are typically constituted as non-profit organizations, meaning they have a fiduciary responsibility to oversee energy market operations for the securement of social welfare rather than for the securement of maximum organizational profits.

Why not simply “correct” the objective function (2.14) by replacing it with AdjTNS (or  $\text{AdjTNS}^R$ )? The key difficulty here is that the LMPs entering into the expression for AdjTNS in (2.10) are solved for *endogenously* within the ISO’s optimization problem as shadow prices on certain “nodal balance conditions” embodying an important physical constraint on power flow (Kirchhoff’s Current Law). By construction, these shadow prices measure the marginal cost to the system of servicing marginal increments of demand at different grid locations. Any explicit appearance of LMPs as endogenous variables in the ISO’s optimization problem apart from their role as shadow prices on nodal balance conditions would destroy their interpretation as shadow prices for these conditions and hence their valid interpretation as system marginal costs.

Sufficient conditions for equivalence between the constrained maximization of  $[\text{AdjTNS}^R + \text{ISONetSurplus}]$  in (2.14) and the similarly constrained maximization of AdjTNS in (2.10) are as follows: (1) LSEs and GenCos report non-strategic demand bids and supply offers, implying that  $\text{AdjTNS}^R = \text{AdjTNS}$ ; and (2) grid congestion is absent, implying all LMPs collapse to a single uniform price level. Given condition (2),  $\text{ISONetSurplus} = 0$  because the total quantity of electric power sold equals the total quantity of electric power bought.

How likely are these two conditions to hold? With regard to (1), Li et al. (2008b) report AMES experiments indicating that strategic profit-seeking GenCos in restructured wholesale power markets typically have an incentive to report supply offers to the ISO that systematically misrepresent their true net surplus outcomes. This is the case whether or not grid congestion is present and whether or not the bid-in demand of LSEs is fixed or price sensitive.

With regard to (2), grid congestion is quite common within restructured wholesale power markets in the U.S. and increasingly in other countries as well. In the presence of grid congestion, LMPs can dramatically separate across the grid, hence the prices paid to the ISO by LSEs can differ substantially from the prices received from the ISO by GenCos. Li et al. (2008b) report consistently positive ISONetSurplus outcomes in a suite of AMES experiments for a dynamic 5-bus test case in which grid congestion persistently arises. It is actually a bit disturbing to realize that maximization of an objective function such as (2.14) could have the unintended consequence of encouraging the emergence and persistence of grid congestion.

What can be done, then, to ensure that the constrained maximization of  $[\text{AdjTNS}^R + \text{ISONetSurplus}]$  at least approximately achieves the similarly-constrained maximization of  $\text{AdjTNS}$ ? One possible way to help ensure  $\text{AdjTNS}^R = \text{AdjTNS}$  would be for an ISO to engage in suitable monitoring of demand bids and supply offers to discourage strategic reporting. Indeed, ISOs in the U.S. now routinely have “market monitoring” units for just this purpose.

According to the ISO market reports (PJM (2009),CAISO (2009),MISO (2009),ISO-NE (2009)) in 2008 for PJM, MISO, ISO-NE and CAISO, the ISO net surplus outcomes are pretty substantial amounts. PJM reports *total congestion costs*, interpreted here as the difference between load payments to the ISO and generation revenues received from ISO, to be \$2.66 billion. Congestion cost in MISO for (2008), defined as “the difference in LMP prices across the interface multiplied by the amount of the (power) transfer,” is approximately \$500 million. A more detailed explanation of net surplus collections in various ISO’s can be found in Li and Tesfatsion (2010)

The net surplus collections for PJM, MISO, ISO-NE, and CAISO, as detailed in the market reports, are largely allocated to FTR/CRR holders. For example, as reported in [PJM (2009), p. 417], PJM allocates its total congestion costs as revenues to FTR holders, including GenCos, LSEs, and pure speculators with no physical generation or load obligations. Any extra amount remaining at the end of the year is allocated to LSEs as payment offsets in accordance with load-ratio shares. Similarly, as reported in [MISO (2009), Section V], MISO distributes its congestion revenues as payments to FTR holders, including holders of special types of FTRs created to protect entities with pre-existing agreements to use the transmission system. Surpluses in one

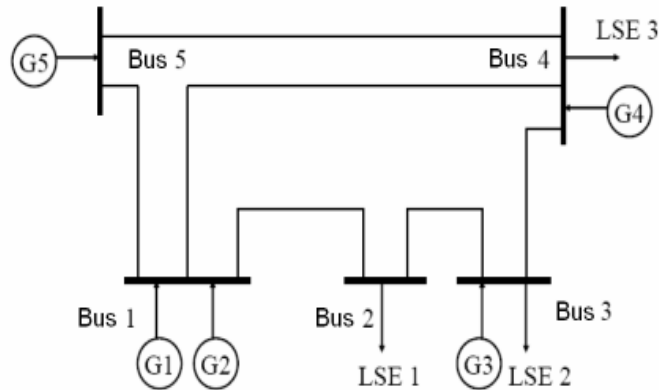

Figure 2.8 5-bus transmission grid for the dynamic 5-bus test case

month are used to fund shortfalls in other months during each year, with FTR payments being reduced pro rata if a shortfall persists at the end of the year.

## 2.5 Experimental Design

All market performance experiments carried out for this study using the AMES test bed are based on a *dynamic 5-bus test case* developed by Li et al. (2008b). This test case is characterized by the following structural, institutional, and behavioral conditions:

- The 5-bus transmission grid configuration is as depicted in Fig. 2.8, with transmission grid, LSE, and GenCo structural attributes as presented in Li et al. (2008b).<sup>10</sup>
- In particular, the maximum operating capacities of the five GenCos depicted in Fig. 2.8 are as follows: 110MW for GenCo 1 (G1); 100MW for GenCo 2 (G2); 520MW for GenCo 3 (G3); 200MW for GenCo 4 (200MW); and 600 MW for GenCo 5 (G5). Note that the next-to-largest GenCo 3 is favorably situated in a potential “load pocket” with respect to the three LSEs.

<sup>10</sup>The 5-bus transmission grid depicted in Fig. 2.8 is due to Lally (2002). This grid configuration is now used extensively in ISO-NE/PJM training manuals to derive quantity and price solutions at a given point in time assuming ISOs have complete and correct information about grid, LSE, and GenCo structural attributes.

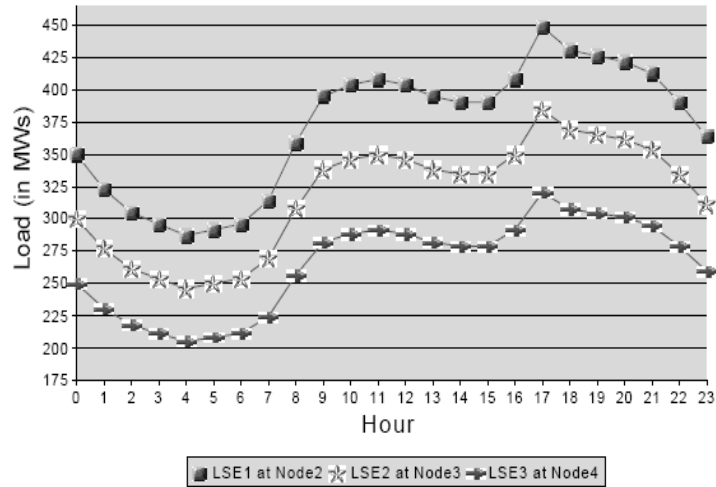

Figure 2.9 Daily LSE fixed demand (load) profiles for the dynamic 5-bus test case

- Also, GenCo 4 (the “peaking unit”) has the most costly generation. Next in line is GenCo 3. The three remaining GenCos 1, 2, and 5 have more moderate costs.
- The daily fixed demand (load) profiles for the three LSEs are the same from one day to the next. As depicted in Fig. 2.9, each daily fixed demand profile peaks at hour 17.<sup>11</sup>
- The learning parameters for each of the five GenCos are set at “sweet spot” values shown in Li et al. (2008b) to be where the GenCos as a whole earn the highest average daily net earnings.<sup>12</sup> The only factor that changes market outcomes from one day to the next is GenCo learning.

Since the GenCos rely on stochastic reinforcement learning to determine their supply offers, multiple runs need to be conducted for each experimental treatment to control for purely random effects. As in Li et al. (2008b), we conduct thirty runs for each treatment using thirty distinct random seeds generated using the standard Java “random” class.<sup>13</sup> Moreover, only

<sup>11</sup>These profile shapes are adopted from a case study presented in (Shahidehpour et al., 2002, p. 296-297).

<sup>12</sup>In particular, we use the GenCo Case(1,1) learning parameter values characterized by  $\alpha = 1$  and  $\beta = 100$  in Li et al. (2008b).

<sup>13</sup>See Li et al. (2008b) for these 30 numerical seed values.

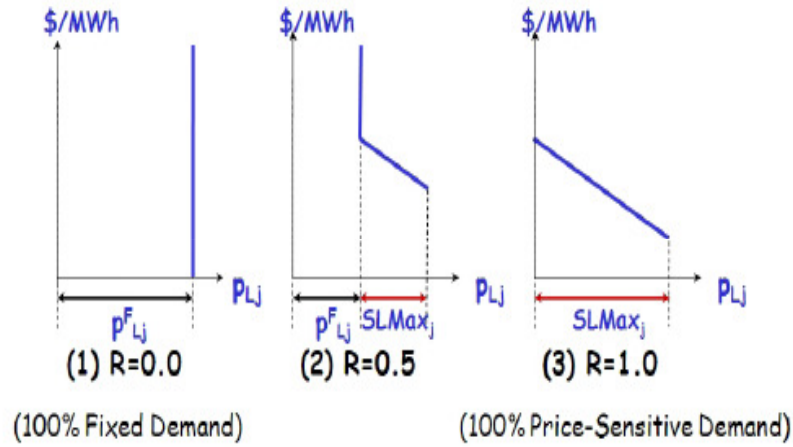

Figure 2.10 Illustration of the construction of the R ratio for measuring relative demand-bid price sensitivity for the special case  $R=0.50$

one of the five possible stopping rules in AMES(V2.01) was flagged for each experimental run: namely, the stopping rule requiring that each run terminate at a user-designated day  $D_{Max}$ . The value set for  $D_{Max}$  in each run was 1000.

The key treatment factor we consider in this study is the ratio  $R$  of maximum potential price-sensitive demand to maximum potential total demand. More precisely, for each LSE  $j$  and each hour  $H$ , let

$$R_j(H) = \frac{SLMax_j(H)}{MPTD_j(H)} \quad (2.15)$$

In (2.15) the expression  $SLMax_j(H)$  denotes LSE  $j$ 's *maximum potential price-sensitive demand* in hour  $H$  as measured by the upper bound of its purchase capacity interval, and

$$MPTD_j(H) = [p_{Lj}^F(H) + SLMax_j(H)] \quad (2.16)$$

denotes LSE  $j$ 's *maximum potential total demand* in hour  $H$  as the sum of its fixed demand  $p_{Lj}^F(H)$  and its maximum potential price-sensitive demand  $SLMax_j(H)$  in hour  $H$ . The construction of the  $R$  ratio is illustrated in Fig. ??.



For our price-sensitive demand experiments we start by setting all of the  $R$  values (2.15) for each LSE  $j$  and each hour  $H$  equal to  $R=0.0$  (the pure fixed-demand case). We then systematically increase  $R$  by tenths, ending with the value  $R=1.0$  (the pure price-sensitive demand case). A positive  $R$  value indicates that the LSEs are able to exercise at least some degree of price resistance.

The maximum potential price-sensitive hourly demands  $SLMax_j(H)$  for each LSE  $j$  are thus systematically increased across experiments. However, we control for confounding effects arising from changes in overall demand capacity as follows: For each LSE  $j$  and each hour  $H$ , the denominator value  $MPTD_j(H)$  in (2.16) is held constant across experiments by appropriate reductions in the fixed demand  $p_{L_j}^F(H)$  as  $SLMax_j(H)$  is increased. Specifically,  $MPTD_j(H)$  is set equal across all experiments to  $BP_{L_j}^F(H)$ , the hour- $H$  fixed-demand level  $BP^F(H)$  for LSE  $j$  specified in Li et al. (2008b) for the dynamic 5-bus test case. Consequently, for each tested  $R$  value,

$$p_{L_j}^F(H) = [1-R] * BP_{L_j}^F(H); \quad (2.17)$$

$$SLMax_j(H) = R * BP_{L_j}^F(H). \quad (2.18)$$

Moreover, as  $R$  is incrementally increased from  $R=0.0$  to  $R=1.0$ , we control for confounding effects arising from changes in the LSEs' price-sensitive demand bids by holding fixed the ordinate and slope values  $\{(c_j(H), d_j(H)): H=00, \dots, 23\}$  for each LSE  $j$ . A listing of the specific numerical values used can be found in Li et al. (2008b).

## 2.6 Experimental Findings

This section uses the experimental design outlined in Section 2.5 for the dynamic 5-bus test case to conduct comparative tests of the five market performance measures developed in Section 2.4.

In particular, we examine outcomes for the Herfindahl-Hirschman Index (HHI) as defined in (2.1), the Lerner Index (LI) as defined in (2.3), the Residual Supply Index (RSI) as defined in (2.4) with only fixed demands included in total demand, the Relative Market Advantage Index (RMAI) as defined in (2.5), and the Adjusted Operational Efficiency Index (AdjOEI) as

defined in (2.11). Average results are reported for R values ranging from R=0.0 (100% fixed demand) to R=1.0 (100% price-sensitive demand).

Average HHI and LI results are reported in Tables 2.1 through 2.4 for both the *competitive benchmark case (no GenCo learning)* and the *learning GenCos case*. The averages are based on 30 runs, each consisting of 1000 time periods (“days”).<sup>14</sup> The only factor causing changes in market outcomes over time in the dynamic 5-bus test case is GenCo learning, hence averages are separately reported for days 10, 50, 100, and 1000 in Tables 2.2 and 2.4 to check the effects of GenCo learning on HHI and LI valuations over time.

As noted in Section 2.4.1, larger HHI values indicate a higher degree of market concentration. Tables 2.1 and 2.2 show that, for each tested R value, HHI is generally higher under GenCo learning. Moreover, for each indicated day, HHI systematically *increases* as R increases. The latter occurs because LSE total cleared demand (fixed plus price sensitive) systematically decreases as R increases, which results in the larger GenCos 3 and 5 supplying a larger *share* of the decreasing electric power output. A key question, addressed below, is whether this higher indicated concentration at higher R values in fact indicates a greater exercise of seller market power.

By design, LI is meant to vary *directly* with seller market power. That is, a *higher* LI value is meant to indicate a *greater* exercise of seller market power.

The average LI results reported in Tables 2.3 and 2.4 systematically *decrease* with increases in R for each indicated day, which suggests that seller market power *decreases* with increases in the price sensitivity of LSE demand. The intuition is that the greater price-sensitivity of demand at higher R values gives LSEs a greater ability to resist higher prices and hence, results in a lowering of average LMP values. This intuition is supported by the AMES experimental findings reported in Li et al. (2008b); average LMP systematically declines (along with LSE total cleared demand) as R increases from R=0.0 to R=1.0 either with or without GenCo learning, although average LMP is much higher with GenCo learning than without for each tested R value.

Comparing these average LI results with the earlier discussed findings for average HHI, it

<sup>14</sup>See Appendix 2.7 for a more detailed explanation of these average outcome calculations.

seems fair to say that HHI is a misleading indicator of seller market power in the context of the dynamic 5-bus test case. A similar conclusion is reached by Borenstein et al. (Borenstein et al., 1999, Section 4) for other market contexts. Conversely, for all of its conceptual faults, the *direction of change* in average LI correctly indicates the direction of change in seller market power.

On the other hand, note in Table 2.4 that average LI for the learning GenCos case systematically increases from day 10 to day 1000 for  $R=0.0$  (100% fixed demand), almost doubling by day 1000. However, average LI first increases and then declines back approximately to its original level for all *positive*  $R$  values (i.e., all cases for which LSE total cleared demand is partially price sensitive). This suggests that price sensitivity of demand is preventing the learning GenCos from reaching and sustaining the high seller market power levels achieved with 100% fixed demand.

RSI values are reported in Table 5.3 for the two largest GenCos 3 and 5, assuming only fixed demands are considered in the measure for LSE total demand. Since LSE fixed demand profiles and GenCo capacities are exogenously given and constant from one day to the next in the dynamic 5-bus test case, RSI is an ex ante measure whose values are also exogenously determined and constant from one day to the next, independently of whether GenCos learn or not. Consequently, it suffices to report RSI values for a typical day  $D$  with attention limited to  $R$  values for which at least a portion of LSE demand is fixed.

By design, RSI is meant to vary *inversely* with seller market power. That is, a *higher* RSI value for some GenCo is meant to indicate a *smaller* potential for the exercise of seller market power. Moreover, an RSI value less than 1 for some GenCo is interpreted to mean that this GenCo has an absolute potential to exercise seller market power because LSE fixed demand cannot be met without this GenCo's capacity.

All of the RSI results in Table 5.3 follow directly from the definition of RSI. In particular, RSI is smaller for the larger GenCo 5 for each hour and each tested  $R$  value. Moreover, for each hour, each GenCo's RSI value systematically *increases* with increases in  $R$  (i.e., with decreases in fixed demand), a direct reflection of the increasing ease with which the smaller fixed demand can be met from remaining GenCo capacity. Consequently, the implication from these RSI

results is that seller market power *decreases* with increases in R.

Moreover, RSI systematically dips down for both GenCos in a neighborhood of the peak demand hour 17 for each tested R value, with RSI falling below 1 in this time interval for R=0.0 (100% fixed demand). Consequently, the implication is that the risk of seller market power is greatest around the peak demand hour 17, particularly so for the case in which all LSE demand is fixed.

How do the RSI results reported in Table 5.3 compare with the LI results reported in Tables 2.3 and 2.4? Both sets of results indicate that seller market power *decreases* with increases in R. Since LI is a direct indicator of seller market power and RSI is an inverse indicator of seller market power, these results support the empirically-based finding of (Sheffrin et al., 2004, pp. 62-63) that the measures LI and RSI are negatively correlated.

Note, however, that RSI exceeds 1 for both GenCos in all hours as soon as R exceeds 0.0, i.e., as soon as a portion of LSE total cleared demand is price sensitive. An unresolved issue is the extent to which seller market power can be exercised by GenCos when their RSI values exceed 1.

As recognized by Sheffrin et al. (2004), a potential weakness of the RSI measure (and the pivotal supplier concept more generally) is that transmission grid congestion is not taken into account. Consequently, RSI does not reflect the possibility that a load pocket situation can emerge that permits a GenCo to exercise substantial seller market power even though its RSI value exceeds 1.

Indeed, based on data from the California wholesale power market, (Sheffrin et al., 2004, p. 63) devise the following rule of thumb for a “workably competitive market:” *The RSI of the largest supplier must not be less than 1.1 for more than 5% of the hours in a year.* However, Table 5.3 indicates that the largest GenCo 5, as well as the next-largest GenCo 3, have RSI values that are well in excess of 1.1 for R values ranging from 0.2 to 0.8. Is it correct to say that the day-ahead market for the dynamic 5-bus test case is “workably competitive” for these higher R values?

The LI results in Table 2.4 suggest, to the contrary, that significant seller market power is still being exercised at these higher R values in the learning GenCos case. The conceptual

problems with LI detailed in Section 2.3 would normally suggest that caution be exercised in interpreting these LI results. However, the detailed results for GenCo reported supply offers obtained by Li et al. (2008b) in a parallel set of AMES experiments clearly show that all of the learning GenCos are indeed exercising at least some seller market power at all tested R values, including R=1.0 (100% price-sensitive demand).

Consider, next, the average RMAI results reported in Table 2.6. By construction, RMAI is intended to measure the ability of sellers to increase their daily net earnings relative to a competitive pricing situation. In particular, applied to the dynamic 5-bus test case, RMAI measures the ability of the learning GenCos to increase their daily net earnings (i.e., their daily net seller surplus) through strategic reporting of supply offers in comparison to the competitive benchmark case in which the ISO knows the GenCos' true costs and capacities. This increase in daily net earnings is normalized by dividing through by the daily net earnings of the GenCos in the competitive benchmark.

The average RMAI results reported in Table 2.6 for R=0.0 (100% fixed demand) indicate that the learning GenCos are able to substantially improve their daily net earnings over time relative to the competitive benchmark. On the other hand, for higher R values their daily net earnings first increase relative to the competitive benchmark but then fall back.

This pattern for average RMAI appears similar to the pattern seen in Table 2.4 for average LI. However, the RMAI standard deviations reported in Table 2.6 are extremely large. This suggests the need to look at the RMAI findings at a more disaggregated level.

For example, one possible cause of the high RMAI standard deviations in Table 2.6 could be that the 30 simulation runs upon which the average RMAI results are based, in fact, constitute two or more distinct "clusters" converging to two or more distinct "attractors" with distinctly different GenCo daily net earnings outcomes relative to the competitive benchmark. The low-earnings attractor could represent cases in which interaction effects among the five learning GenCos hinder the GenCos from co-learning how to implicitly collude on reported supply offers that ensure high daily net earnings.

The average RMAI results reported in Table 2.6 for each indicated day also show that average RMAI exhibits a rather substantial *increase* as R varies from R=0.0 to R=1.0, i.e.,

as LSE total cleared demand moves from 100% fixed demand to 100% price-sensitive demand. On the other hand, an examination of the corresponding results for simple *Market Advantage (MA)* (i.e., the numerator of RMAI) in Table 2.7 shows the more intuitively expected finding that—in level rather than relative terms—the daily net earnings of the GenCos substantially *decrease* as R varies from R=0.0 to R=1.0.

The problem here is that the denominator of RMAI is not invariant to changes in R, implying that two potentially offsetting effects are occurring at the same time. As R increases from R=0.0 to R=1.0, LSE total cleared demand decreases rather substantially in the competitive benchmark, as do the corresponding daily net earnings of the GenCos. This means that the decreasing gains from learning at each successively higher R value are being normalized by an ever smaller competitive benchmark base value. Table 2.6 suggests that the latter effect dominates, resulting in larger RMAI values as R increases. The bottom line is that cross-R comparisons of average RMAI are not very meaningful.

Finally, consider the average AdjOEI results reported in Table 2.8. These results display systematic patterns that resemble some of the patterns seen for average MA in Table 2.7. For example, for R=0.0 (100% fixed demand), AdjOEI increases for each successive indicated day. Moreover, for each indicated day, AdjOEI exhibits a rather substantial decrease as R varies from R=0.0 (100% fixed demand) to R=1.0 (100% price sensitive demand).

Also, since all of the average AdjOEI results in Table 2.8 are positively valued, the numerator and denominator for AdjOEI must have the same signs. Consequently,

$$(AdjOIE < 1) \Leftrightarrow |AdjTNS^R| < |AdjTNS^C| \quad (2.19)$$

Note that AdjOEI drops below 1 at R=1.0 for each successive indicated day.

However, due to the conceptual problems analyzed at some length in Section 2.4.2, it is difficult to use relation (2.19) to draw inferences about operational efficiency. The critical difficulty here is that the denominator of AdjOEI—namely,  $AdjTNS^C$ —does *not* necessarily represent maximum AdjTNS. Rather,  $AdjTNS^C$  represents the AdjTNS outcome for the competitive benchmark case when the ISO undertakes the constrained maximization of [AdjTNS + ISONetSurplus]. In the presence of grid congestion, ISONetSurplus can depart substantially

from zero. For example, in parallel AMES experiments reported in Li et al. Li et al. (2008b) for the dynamic 5-bus test case, the branch connecting bus 1 to bus 2 is nearly always congested around the peak load hour 17 for both the competitive benchmark and learning GenCos cases, resulting in large positive ISONetSurplus outcomes.

The bottom line is that the denominator of AdjOEI needs to be replaced with a more reliable proxy for maximum achievable adjTNS.

## 2.7 Calculation of Reported Data Averages and Standard Deviations

Below we explain how we obtained the average Lerner Index (LI) results reported in Table 2.4, together with standard deviations, for any specified day D and any specified R value. Average and standard deviation calculations for the remaining ex post market performance measures are similarly obtained.

First, for each run  $r$ , for each hour  $H$  of day  $D$ , and for each GenCo  $i$  with a positive cleared power supply  $p_{Gi}$  for run  $r$  during hour  $H$ , determine GenCo  $i$ 's Lerner Index  $LI(i,r,H,D)$  as in (2.3). Second, for each hour  $H$  and for each GenCo  $i$ , determine the average of GenCo  $i$ 's Lerner Indices  $LI(i,r,H,D)$  across all of the runs  $r$  for which he had a positive cleared power supply for hour  $H$ . Third, for each hour  $H$ , determine the average of these run-averaged Lerner Indices across all GenCos  $i$  who have a positive cleared power supply during hour  $H$  for at least one run  $r$ . Finally, determine the average of these GenCo-averaged and run-averaged Lerner Indices across all 24 hours  $H$  to get  $AvgLI(D)$ .

For example, if all of the five GenCos have positive cleared supplies for each hour  $H$  of day  $D$  in each run  $r$ ,  $AvgLI(D)$  can be expressed as follows:

$$AvgLI(D) = \frac{\left[ \sum_{H=00}^{23} \sum_{i=1}^5 \sum_{r=1}^{30} [LI(i, r, H, D)] \right]}{24 * 5 * 30} \quad (2.20)$$

The corresponding standard deviation  $StDevLI(D)$  is then calculated using the “N” definition (i.e., division by the total number  $N=[24*5*30]$  of summed terms rather than  $N-1$ ), as follows:

$$\sqrt{\frac{\left[ \sum_{H=00}^{23} \sum_{i=1}^5 \sum_{r=1}^{30} [LI(i, r, H, D) - AvgLI(D)]^2 \right]}{24 * 5 * 30}} \quad (2.21)$$

## Acknowledgment

The authors particularly thank Hongyan Li for many useful discussions related to the topic of this study. We are also grateful to Jim McCalley and other members of our NSF energy project team for helpful comments.

Table 2.1 Dynamic 5-Bus Test Case: Herfindahl-Hirschman Index (HHI) results for a typical day D for the competitive benchmark case (no GenCo learning) as R varies from R=0.0 (100% fixed demand) to R=1.0 (100% price-sensitive demand)

Day	R = 0.0	R = 0.2	R = 0.4	R = 0.6	R = 0.8	R = 1.0
D	4,037.48 (92.33)	4,190.91 (287.38)	4,640.96 (649.97)	5,418.82 (823.19)	6,422.01 (585.55)	6,558.37 (453.14)

Table 2.2 Dynamic 5-Bus Test Case: Average Herfindahl-Hirschman Index (HHI) results with standard deviations on successive days for the learning GenCos case as R varies from R=0.0 (100% fixed demand) to R=1.0 (100% price-sensitive demand)

Day	R = 0.0	R = 0.2	R = 0.4	R = 0.6	R = 0.8	R = 1.0
10	4,314.10 (910.52)	4,848.53 (1,406.28)	6,135.92 (1,883.14)	6,933.69 (2,109.11)	7,263.76 (2,235.60)	7,660.50 (2,158.85)
50	4,069.60 (970.27)	4,548.91 (1,528.33)	5,377.97 (2,174.75)	6,300.46 (2,347.72)	6,740.58 (2,426.82)	7,266.92 (2,529.18)
100	3,945.12 (758.27)	4,654.25 (1,291.36)	6,052.07 (1,978.25)	6,742.74 (2,175.19)	6,992.86 (2,165.93)	7,806.67 (2,150.25)
1000	3,141.35 (916.17)	4,619.71 (1,501.05)	5,977.48 (1,987.65)	6,953.54 (2,230.85)	7,200.11 (2,316.82)	7,750.79 (2,060.53)

Table 2.3 Dynamic 5-Bus Test Case: Lerner Index (LI) results for a typical day D for the competitive benchmark case (no GenCo learning) as R varies from R=0.0 (100% fixed demand) to R=1.0 (100% price-sensitive demand)

Day	R = 0.0	R = 0.2	R = 0.4	R = 0.6	R = 0.8	R = 1.0
D	0.0053 (0.0431)	0.0035 (0.0383)	0.0029 (0.0320)	0.0022 (0.0237)	0.00 (0.00)	0.00 (0.00)



Table 2.4 Dynamic 5-Bus Test Case: Average Lerner Index (LI) results with standard deviations on successive days for the learning GenCos case as R varies from R=0.0 (100% fixed demand) to R=1.0 (100% price-sensitive demand)

Day	R = 0.0	R = 0.2	R = 0.4	R = 0.6	R = 0.8	R = 1.0
10	0.3098 (0.2646)	0.2961 (0.2535)	0.2498 (0.2432)	0.1837 (0.2181)	0.1589 (0.2035)	0.1338 (0.1866)
50	0.3356 (0.2905)	0.3271 (0.2734)	0.3206 (0.2680)	0.2542 (0.2622)	0.2173 (0.2482)	0.1610 (0.2142)
100	0.3979 (0.3169)	0.3286 (0.2657)	0.2816 (0.2571)	0.2364 (0.2497)	0.2024 (0.2291)	0.1491 (0.1992)
1000	0.6049 (0.2861)	0.3200 (0.2892)	0.2433 (0.2517)	0.1873 (0.2321)	0.1621 (0.2209)	0.1266 (0.1947)

Table 2.5 Dynamic 5-Bus Test Case: Residual Supply Index (RSI) values by hour for the two largest GenCos 3 and 5 during a typical day D for the learning GenCos case as R varies from R=0.0 (100% fixed demand) to R=0.80 (20% fixed demand)

Hour	R=0.0		R=0.2		R=0.4		R=0.6		R=0.8	
	RSI(G3)	RSI(G5)	RSI(G3)	RSI(G5)	RSI(G3)	RSI(G5)	RSI(G3)	RSI(G5)	RSI(G3)	RSI(G5)
00	1.12	1.03	1.40	1.29	1.87	1.72	2.81	2.58	5.61	5.17
01	1.22	1.12	1.52	1.40	2.03	1.87	3.04	2.80	6.08	5.60
02	1.29	1.19	1.61	1.48	2.15	1.98	3.22	2.96	6.44	5.93
03	1.33	1.22	1.66	1.53	2.21	2.04	3.32	3.05	6.63	6.11
04	1.37	1.26	1.71	1.57	2.28	2.10	3.42	3.15	6.84	6.30
05	1.35	1.24	1.68	1.55	2.25	2.07	3.37	3.10	6.73	6.20
06	1.33	1.22	1.66	1.53	2.21	2.04	3.32	3.05	6.63	6.11
07	1.25	1.15	1.56	1.44	2.08	1.92	3.13	2.88	6.25	5.76
08	1.09	1.01	1.37	1.26	1.82	1.68	2.74	2.52	5.47	5.04
09	0.99	0.92	1.24	1.15	1.66	1.53	2.49	2.29	4.97	4.58
10	0.97	0.90	1.22	1.12	1.62	1.49	2.43	2.24	4.86	4.48
11	0.96	0.89	1.20	1.11	1.60	1.48	2.41	2.21	4.81	4.43
12	0.97	0.90	1.22	1.12	1.62	1.49	2.43	2.24	4.86	4.48
13	0.99	0.92	1.24	1.15	1.66	1.53	2.49	2.29	4.97	4.58
14	1.01	0.93	1.26	1.16	1.68	1.54	2.52	2.32	5.03	4.63
15	1.01	0.93	1.26	1.16	1.68	1.54	2.52	2.32	5.03	4.63
16	0.96	0.89	1.20	1.11	1.60	1.48	2.41	2.21	4.81	4.43
17	0.88	0.81	1.09	1.01	1.46	1.34	2.19	2.02	4.38	4.03
18	0.91	0.84	1.14	1.05	1.52	1.40	2.28	2.10	4.56	4.20
19	0.92	0.85	1.15	1.06	1.54	1.41	2.30	2.12	4.61	4.24
20	0.93	0.86	1.16	1.07	1.55	1.43	2.33	2.14	4.66	4.29
21	0.95	0.88	1.19	1.10	1.59	1.46	2.38	2.19	4.76	4.38
22	1.01	0.93	1.26	1.16	1.68	1.54	2.52	2.32	5.03	4.63
23	1.08	0.99	1.35	1.24	1.80	1.66	2.70	2.49	5.40	4.98

Table 2.6 Dynamic 5-Bus Test Case: Average Relative Market Advantage Index (RMAI) results with standard deviations on successive days for the learning GenCos case as R varies from R=0.0 (100% fixed demand) to R=1.0 (100% price-sensitive demand)

Day	R = 0.0	R = 0.2	R = 0.4	R = 0.6	R = 0.8	R = 1.0
10	139.06 (416.49)	424.86 (1,201.19)	719.19 (2,449.79)	2,006.50 (6,627.53)	1,873.17 (6,308.01)	3,116.74 (11,478.58)
50	276.60 (748.42)	697.52 (2,112.42)	1,524.85 (4,608.18)	3,443.01 (10,471.74)	2,649.94 (8,590.80)	3,707.51 (11,909.11)
100	362.40 (829.61)	569.93 (1,523.32)	899.26 (2,724.74)	2,379.93 (6,752.46)	2,348.32 (6,817.43)	3,069.37 (10,091.30)
1000	878.59 (1,513.36)	906.97 (2,906.84)	776.06 (2,657.66)	1,968.14 (6,590.91)	1,737.53 (6,389.19)	2,918.16 (12,095.18)

Table 2.7 Dynamic 5-Bus Test Case: Average Market Advantage (MA) results with standard deviations on successive days for the learning GenCos case as R varies from R=0.0 (100% fixed demand) to R=1.0 (100% price-sensitive demand) GenCo MAI values

Day	R = 0.0	R = 0.2	R = 0.4	R = 0.6	R = 0.8	R = 1.0
10	146,808.50 (296,766.02)	69,037.57 (106,469.42)	32,372.44 (48,622.70)	21,121.70 (40,103.79)	15,277.52 (27,527.92)	8,274.85 (16,626.61)
50	175,500.45 (353,928.49)	69,575.46 (88,212.41)	43,939.71 (63,760.51)	27,184.67 (45,737.52)	16,558.95 (26,863.22)	7,717.03 (15,060.39)
100	307,262.12 (556,696.68)	68,976.70 (97,491.68)	36,528.33 (59,562.84)	24,177.05 (43,029.44)	16,067.05 (27,086.31)	8,172.46 (16,330.44)
1000	469,927.68 (1,513.36)	94,377.59 (165,337.31)	34,959.28 (59,932.77)	22,404.63 (42,864.65)	15,472.34 (27,334.08)	8,274.95 (16,171.00)

Table 2.8 Dynamic 5-Bus Test Case: Average Adjusted Operational Efficiency Index (AdjOEI) results with standard deviations on successive days for the learning GenCos case as R varies from R=0.0 (100% fixed demand) to R=1.0 (100% price-sensitive demand)

Day	R = 0.0	R = 0.2	R = 0.4	R = 0.6	R = 0.8	R = 1.0
10	2.5045 (1.3451)	2.1544 (1.0462)	1.7395 (0.6554)	1.2741 (0.1981)	2.4764 (1.2885)	0.6155 (0.2203)
50	2.9325 (1.8837)	1.8717 (0.5695)	1.5878 (0.4312)	1.3599 (0.3191)	2.8254 (1.8416)	0.5936 (0.2677)
100	4.6678 (2.4285)	1.8240 (0.9039)	1.5484 (0.5006)	1.2747 (0.2716)	2.4697 (1.5602)	0.6299 (0.2424)
1000	6.0972 (1.1949)	2.6831 (1.8110)	1.6238 (0.7226)	1.2289 (0.2212)	2.2098 (1.2518)	0.6709 (0.2358)

## CHAPTER 3. Financial Risk Management in Electric Restructured Power Markets: Literature Review

### 3.1 Introduction to Restructured Power Markets

This chapter presents a survey of work done by various researchers who investigate the risk management issues of market participants. The first half of this chapter focuses on electric power derivatives and their pricing, providing a concise review of various models developed to predict/forecast spot prices. The second half discusses the use special financial instruments called *Financial Transmission Rights* (FTRs) in dealing with price risks and the associated issues of market efficiency.

The literature review/essay is organized as follows. In section 2, a brief review of the need for hedging in deregulated power markets is presented. In section 3, a summary of characteristics idiosyncratic to electric power markets is presented, followed by a review of various models used by different researchers to price power derivatives. In section 4, a brief description of the causes of congestion risk is presented followed by the definition of FTRs. In section 5, the risk hedging function of FTRs is presented in some detail. Section 6 presents different ways that market participants can avail to acquire FTRs. Section 7 presents criticism of the FTR auction model as related to its hedging functionality. Section 8 presents a survey of research on market power exacerbation due to FTRs, and also the implications of ISO's FTR allocation policies on the overall market efficiency. Section 9 presents a survey of research on transmission expansion incentives provided by issuing of FTRs.

### 3.2 Electric Power Derivatives

Electric power is not a tradeable asset in the classical sense since storage costs are prohibitively high. This is a very fundamental factor distinguishing electric power markets from other markets. Hydro-electricity can be argued to provide “storable” electricity because of the water held by a dam. However, only 6% of electricity production in the US comes from hydro-electric power plants and hence, can be neglected. The non-storability feature of electricity adds volatility to electric power spot prices because inventories cannot be used to smooth demand or supply shocks. However, the absence of storage lends predictability to inter-temporal variation in electric power prices, such as between daytime and nighttime.

The transmission constraints, as also the physics governing the functioning of underlying power grid affect very much the geographical extent of the market. These constraints make the transportation of electricity extremely uneconomical among certain regions. The electric power contracts and prices thus become extremely localized, i.e. strongly dependent of local demand and supply conditions.

Price spikes can appear abruptly and erratically in electric power markets. The price spikes generally prevail for a very short time (hours), mostly due to sudden supply/demand shocks and then return to “normal” levels. Electric power prices are believed by many to follow mean-reverting process. However, even accounting for seasonal variation, price spikes can appear at times due to generation and/or transmission line outages.

As a consequence, market for financial instruments has been created to allow the market participants to hedge against price risks. The basic tradeable instruments in the electric power markets are forward and futures contracts with delivery of electricity over a period of time. The arbitrage opportunities across time and space, which are based on storability and transportability are extremely limited, if not totally eliminated in electric power markets. Hence, the relationship between spot and future electric power prices is not the same as for other commodities. The issues mentioned above are idiosyncratic to electricity markets and magnify the complexity of forecasting future spot prices or pricing of derivatives.

### 3.3 Pricing of Electric Power Derivatives

#### 3.3.1 Electricity versus Other Commodity Pricing

As explained by Eydeland and Geman (1998), the following problems occur in pricing electric power derivatives because of non-storability, which are not common to other commodities.

- The notion of convenience yield was introduced by the economists Kaldor and Working to capture the benefit from owning a capacity minus the cost of storage. However, due to prohibitively high storage costs the idea of convenience yield cannot be used in valuation of electric power options.
- The no-arbitrage argument used to establish a relationship, which prevails at equilibrium, between spot and future prices of stocks etc., breaks down in the case of electricity markets. The no-arbitrage models rely on the asset to be bought (sold) at time  $t$  and held until maturity  $T$ .
- Another consequence of non-storability is that the famous delta-hedging method cannot be implemented in electricity markets as it entails holding commodity for a certain time.

#### 3.3.2 Electricity Price Patterns

Various models developed by researchers to value electric power derivatives recognize the following patterns in electricity prices. These patterns have been observed in all the deregulated markets to varying degrees.

- Seasonality: It is a well established fact that electric energy consumption is the highest during summer months.
- Mean Reversion: Electric power prices can typically be approximated by estimating production costs. Unless a systematic market-wide increase in production costs occurs, the electric power prices should hover around the respective production costs under normal demand conditions. Hence, the prices should stabilize around average production costs over time.

- Small fluctuations around the mean due to intra-day difference in demand or weather conditions. For example, there is a noticeable and consistent difference between daytime and nighttime prices.
- Price spikes are observed rather frequently due to sudden demand or supply shocks. However, these price increases are not permanent. The most famous example is that of the US midwest in 1998 when spot prices jumped from about \$30-40 per MWh to more than \$2000-4000 per MWh in a matter of hours. The reasons cited for the same include shutting down of nuclear power plant in Ohio due to tornadoes. The prices returned to somewhat normal level of about \$200 per MWh in a couple of days.

Any attempt to reasonably value power derivatives must account for the above mentioned trends, with mean reversibility and jumps being the most important factors.

### 3.3.3 Pricing Models

To price electricity derivatives, it is necessary to characterize the evolution of the price of electricity through time. The pricing approaches generally fall into two classes of models: spot-based models and forward-based models. Spot models are appealing since they tend to be quite tractable and also allow for a good mathematical description of the problem in question. In Eydeland and Geman (1998) the authors present a diffusion process with stochastic volatility, which accounts for mean reversion, and the spot prices follow Brownian motion. The model can be written as,

$$dS(t) = \mu(S_t, t)dt + \sigma S(t)dW_t \quad (3.1)$$

where  $\mu(S_t, t)$  is the mean reverting component and  $W_t$  is a Brownian motion. The term  $\sigma$  is a constant. Significant contributions have been made by Schwartz (1997), who introduces an Ornstein-Uhlenbeck type of model, which accounts for the mean reversion of prices. In Lucia and Schwartz (2002) the authors extend the model to a two-factor model, which incorporates a deterministic seasonal component as well. The class of diffusion models, as noted by Barlow (2002), do not give rise to price spikes as noticed in California or Alberta markets.

Geman (1994) notes, “Since extreme temperatures, and hence, an extreme power demand, happen to coincide with outages in power generation and/or transmission, the dynamics of electricity spot prices can be advantageously represented by a jump-diffusion process.” In a jump diffusion model, price change can be divided into the following: (1) A continuous price diffusion process modeled by Geometric Brownian Motion with mean reversion and a volatility term structure. This component captures the electric power price dynamics without spikes (as detailed before), and (2) A discontinuous jump process modeled by a Poisson distribution, which might be a result of outages, transmission constraints, etc. Eydeland and Geman (1998) present a simple representation of a jump-diffusion process written as follows.

$$dS_t = \mu S_t dt + \sigma S_t dW_t + U S_t dN_t \quad (3.2)$$

where the diffusion component is represented by a Poisson process ( $N_t$ ) with a random magnitude.  $U$  is a real valued random variable representing the sign and magnitude of the jump. The model so described is the same as Merton’s jump diffusion model, which assumes independence between the two components. The assumption though, is not a fair one in electricity markets, for example, prices are highly unlikely to spike at nighttime with low levels of demand.

Geman and Roncoroni (2006) follow similar process modeling spikes via jump process and are able to successfully fit spot prices collected from several markets. Cartea and Figueroa (2005) present a model that captures mean reversion, jumps and seasonality while calibrating the parameters to the England and Wales market. Barlow (2002) presents a model of pure diffusion model for spot electric power prices, which exhibit spikes. The model starts from a simple demand and supply model for electricity and uses nonlinear Ornstein-Uhlenbeck type of mean-reverting process. The model, however, is stationary and does not provide a satisfactory relationship between spot and futures prices.

Routledge et al. (1999) consider equilibrium model of electricity contracts. They focus on linkage between natural gas and electricity markets (spark spread) because natural gas can be stored and converted into electricity.

### 3.3.4 Risk Premium

Financial markets have typically been established to facilitate the transfer of risk, where forward premium represents the compensation required, in equilibrium, by those willing to bear the risk. Given that spikes are relatively more frequent in electricity markets compared to other commodities, electric power forward prices must contain risk premium. Empirical work done by Pirrong and Jermakyan (2000) provides evidence of existence of risk premia (seasonal) in Pennsylvania, New Jersey, Maryland (PJM) markets.

Bessembinder and Lemmon (2002) argue that the arbitrage argument, which can be made for other commodities, does not hold for pricing electric power derivatives. The well known cost-of-carry relationship linking spot and forward prices cannot be applied because electricity cannot be stored (economically) to be later sold at forward price. Hence the cost of carry approach needs to be reformulated as done by Geman:

$$ForwardPrice = SpotPrice + \pi(t, T) \quad (3.3)$$

where risk premium is represented by  $\pi(t, T)$  and depends on time to maturity of the forward contract. Bessembinder and Lemmon (2002) present an equilibrium model implying that forward power price is downward biased predictor of the future spot price if the expected power demand is low and demand risk is moderate. The forward premium increases when the expected demand or demand variance is high. They present some empirical evidence of the same for forward prices during summer months in PJM market. Longstaff and Wang (2004) also point out the existence of very high risk premiums paid in PJM electricity forward markets to compensate the sellers for extreme shocks.

## 3.4 Financial Risk Management in Wholesale Power Markets

Based on Yu et al. (2010) we present a scenario that considers the short-term risk-management problems faced by a GenCo operating in a wholesale power market with congestion managed by LMP (see Hogan (1992b), Litvinov et al. (2004), Finney et al. (1997), Wu et al. (2005), Cheng and Overbye (2006), Chen et al. (2002), Conejo et al. (2005)). Consider the 5-bus scenario depicted in Fig. 3.1. In this scenario a particular GenCo owns a nuclear power plant, G3, located



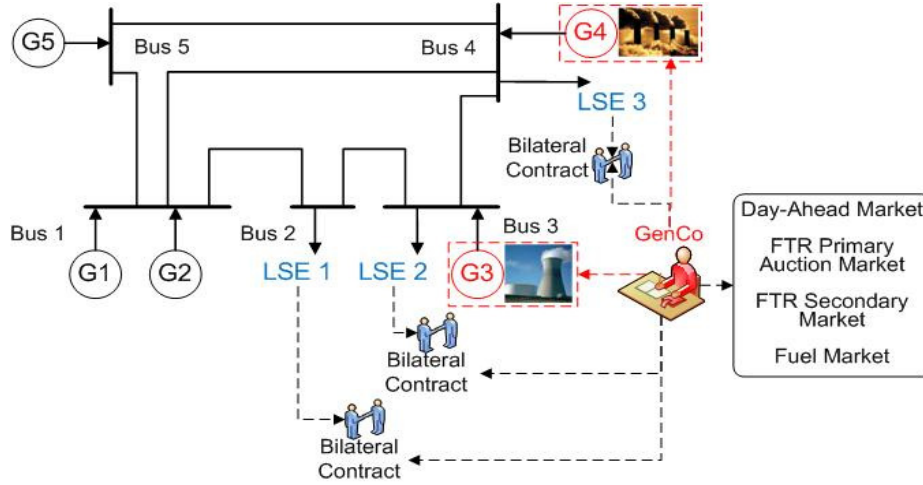

Figure 3.1 Illustrative risk management problem for a GenCo operating in a 5-bus wholesale power market under LMP.

at bus 3, and a coal-fired power plant, G4, located at bus 4. Other generation plants G1, G2, and G5 are located at buses 1 and 5. There are also three LSEs 1, 2, and 3 located at buses 2, 3, and 4 whose demand for power in each hour is assumed to be fixed, i.e., not sensitive to price changes. Each transmission line has an associated thermal limit (not indicated in the figure).

Suppose that the GenCo is required each day to report a 24-hour supply offer to the day-ahead energy market for its coal-fired power plant, and it does this by reporting strategically in an attempt to secure for itself the highest possible net earnings. That is, for its coal-fired plant the GenCo can report higher-than-true marginal costs of production or less-than-true maximum operating capacity. On the other hand, suppose the GenCo's daily 24-hour supply of nuclear power is externally determined in accordance with safety regulations.

Given all supply offers for all generation plants and total LSE load for any given hour  $H$  of the day-ahead energy market, the ISO solves a standard *DC optimal power flow (DC OPF)* optimization problem that involves the minimization of (reported) generation production costs subject to network constraints, (reported) generation operating capacity limits, and a balancing condition requiring that the total supply of power just equal total load. The solution of this problem determines for hour  $H$  the GenCo's dispatch levels for nuclear power at bus 3 and coal-

fired power at bus 4, as well as dispatch levels for all other generation plants and a *Locational Marginal Price (LMP)* in \$/MWh at each bus. Given congestion anywhere on the 5-bus grid in a particular hour, the LMP solutions determined via DC OPF for this hour will “separate,” meaning that the LMPs at two or more buses will deviate from each other. The price received by the GenCo for its dispatched supply of nuclear power at bus 3 is the LMP at bus 3, and the price received by the GenCo for its dispatched supply of coal-fired power at bus 4 is the LMP at bus 4.

Clearly drops in the LMP value at either bus 3 or bus 4 result in lower net earnings for the GenCo, all else equal. Moreover, lower LMP values over time result in lower net earnings for the GenCo, all else equal. Finally, increases in the GenCo’s fuel input costs lower its net earnings, all else equal. Hereafter the possibility that the GenCo receives lower net earnings due to adverse price movements, either output or input, will be called the GenCo’s *price risk*.

The GenCo can attempt to manage its price risk by engaging in physical or financial bilateral transactions<sup>1</sup> with other market participants. For example, the GenCo could write a contract  $C$  with an LSE  $j$  on day  $D$  specifying that the GenCo will inject  $q$  MWs of power at bus 3 and/or bus 4 during a specific hour  $H$  of day  $D+1$  for a specific *strike price*  $p$  (\$/MWh), and the LSE  $j$  will in turn withdraw power  $q$  at its bus location during hour  $H$  of day  $D+1$  and pay to the GenCo the strike price  $p$ .

However, this bilateral contracting is complicated by the fact that injections and withdrawals of power on the transmission grid are in fact charged in accordance with LMP. To ensure the strike price  $p$  can be implemented in hour  $H$  of day  $D+1$  under LMP, the bilateral contract  $C$  needs to incorporate an appropriate *contract-for-difference (CFD)* clause ensuring the effective price is  $p$  even if the LMP received by GenCo  $i$  or paid by LSE  $j$  differs from  $p$ . Further, given the possibility of LMP separation across buses, “making whole” the strike price  $p$  in hour  $H$  of day  $D+1$  also requires additional contracts, such as *Financial Transmission Rights (FTRs)* associated with pairs of buses  $k$  and  $m$ . Roughly stated (ignoring network

<sup>1</sup>In U.S. ISO-managed energy regions such as (MISO, , p. 15), a bilateral transaction that involves the physical transfer of energy through a transmission provider’s region is referred to as a *physical bilateral transaction*. Bilateral transactions that only transfer financial responsibility within and across a transmission provider’s region are referred to as *financial bilateral transactions*.

losses), a 1-MW FTR from a bus  $k$  to a bus  $m$  in hour  $H$  of day  $D+1$  is a financial contract that entitles its holder to receive (or pay) compensation (\$/h) in amount  $1\text{-MW} \times [\text{LMP}_m - \text{LMP}_k]$  for hour  $H$  of day  $D+1$ .

An appropriate combination of an FTR contract and a CFD-extended version of the bilateral contract  $C$  can ensure that the GenCo receives the strike price  $p$  for its injection of  $q$  MWs in hour  $H$  of day  $D+1$ , thus reducing its price risk. However, this reduction in price risk needs to be balanced against the cost of acquiring the supporting contracts.

In summary, for the scenario at hand, at any given time the GenCo's asset portfolio will include physical assets (power plants G3 and G4), a futures contract (cleared supply offer) for sales in the day-ahead energy market, and various forms of bilateral contracts and FTRs.

### 3.5 Risk-Hedging Through Bilateral and FTR Contracts

Consider a GenCo  $i$  and an LSE  $j$  that are participants in an ISO-managed day-ahead energy market with locational marginal pricing. GenCo  $i$  receives a price  $\text{LMP}_i$  for each MW of power it injects at its bus  $i$ , and LSE  $j$  pays a price  $\text{LMP}_j$  for each MW of power that its retail customers withdraw at bus location  $j$ , where these LMP values are determined by the ISO through an appropriate OPF calculation.

Suppose GenCo  $i$  wishes to use bilateral contracts to manage its (output) price risk. In particular, suppose GenCo  $i$  enters into a contract  $C$  with LSE  $j$  on day  $D$  specifying that GenCo  $i$  will inject  $q$  MWs of power at bus  $i$  during a specific hour  $H$  of day  $D+1$  for a specific *strike price*  $p$  (\$/MWh). In turn, the contract  $C$  obliges LSE  $j$  to purchase  $q$  MWs of power at bus location  $j$  during hour  $H$  of day  $D+1$  and to pay to GenCo  $i$  the strike price  $p$  for each MW of this withdrawn power.

As noted in Section, the implementation of this bilateral contract is complicated by the fact that power injected into or withdrawn from the transmission network is priced by means of LMPs. Consider, first, the case in which there is no network congestion during the designated hour  $H$ . In this case all bus LMPs for hour  $H$  collapse to a single value, say  $\text{LMP}^*$ . If  $\text{LMP}^*$  differs from the contract strike price  $p$ , GenCo  $i$  and LSE  $j$  will need to extend their original bilateral contract  $C$  to a contract  $C^*$  incorporating a CFD clause stipulating that either party

will be compensated by the other for excessive or insufficient payment in relation to the intended strike price  $p$ .

For example, suppose  $LMP^* > p$ , implying that LSE  $j$  pays more than the strike price  $p$  for the power its retail customers withdraw at bus  $j$  and GenCo  $i$  receives more than the strike price  $p$  for the power it injects at bus  $i$ . The CFD clause should then require GenCo  $i$  to compensate LSE  $j$  with an extra payment  $q \cdot [LMP^* - p]$ , thus “making whole” LSE  $j$  by ensuring the effective price paid for the contracted power amount  $q$  is the strike price  $p$ . Similarly, in the reverse case  $p > LMP^*$ , the CFD clause should require LSE  $j$  to “make whole” GenCo  $i$  with an extra payment  $q \cdot [p - LMP^*]$ .

Hence, in the absence of congestion, the extended contract  $C^*$  provides a perfect hedge for GenCo  $i$  and LSE  $j$  against price risk in the form of deviations of  $LMP^*$  from  $p$ . If network congestion arises in hour  $H$ , however,  $C^*$  will not be enough to ensure a complete hedging against this price risk. Congestion can lead to divergence between the  $LMP_i$  at bus  $i$  received by GenCo  $i$  and the  $LMP_j$  at bus  $j$  paid by LSE  $j$ . In particular, the  $LMP_i$  at bus  $i$  could drop below  $p$  while at the same time the  $LMP_j$  at bus  $j$  exceeds  $p$ , implying that both parties to the contract are in need of “make whole” payments.

This gap in hedge coverage can be filled by an appropriate parallel purchase of FTRs in the form of obligations, the only form of FTR to be considered below. An FTR in the form of an obligation entitles its holder to compensation (or obliges its holder to pay) based on the difference in LMP outcomes between two specified bus locations for some specified hour.<sup>2</sup> For example, suppose a market participant holds an FTR position of  $q$  MWs for a source bus  $i$  and a sink bus  $j$  for a particular hour  $H$ . The holder is then entitled to receive a compensation of

$$\pi_{ij} = q \cdot [LMP_j - LMP_i] \quad (\$/h) \quad (3.4)$$

from the ISO if  $\pi_{ij} \geq 0$ ; otherwise the holder must pay the ISO the amount  $-\pi_{ij}$ . Since bus LMPs collapse to a single value across the transmission network in the absence of congestion (ignoring typically small network losses), FTR compensations and payments only take place in

<sup>2</sup>More precisely, if network losses are considered, these compensations or payment obligations are based on the congestion components of LMPs rather than the LMP values per se. This complication is ignored in this introductory presentation.

congested conditions.

How might GenCo  $i$  and LSE  $j$  accomplish a complete hedge of their price risk through a combined holding of an appropriate CFD-extended bilateral contract and an FTR holding? Suppose GenCo  $i$  acquires an FTR position of  $q$  MWs from bus  $i$  to bus  $j$  on day  $D$  for hour  $H$  of the day-ahead energy market on day  $D+1$ . GenCo  $i$ 's net receipts on day  $D+1$  from its energy injection and its FTR holding are then as follows:

$$q \cdot \text{LMP}_i + q \cdot [\text{LMP}_j - \text{LMP}_i] = q \cdot \text{LMP}_j . \quad (3.5)$$

Consequently, under the FTR, GenCo  $i$ 's sale price in hour  $H$  of day  $D+1$  has been effectively changed from  $\text{LMP}_i$  to  $\text{LMP}_j$ , the purchase price paid by LSE $_j$  at bus  $j$  in hour  $H$  of day  $D+1$ . Suppose, in addition, that GenCo  $i$  and LSE $_j$  extend their bilateral contract  $C$  with the following type of CFD clause applying only to bus  $j$ : GenCo  $i$  makes a payment to LSE  $j$  in amount  $q \cdot [\text{LMP}_j - p]$  if  $\text{LMP}_j > p$  or receives a payment from LSE  $j$  in amount  $q \cdot [p - \text{LMP}_j]$  if  $p > \text{LMP}_j$ . This combination of contracts ensures that the price received by GenCo  $i$  and paid by LSE  $j$  for the contracted power level  $q$  in hour  $H$  of day  $D+1$  is precisely  $p$ .

### 3.6 FTR Acquisition Process

A Financial Transmission Rights contract has the following specifications for GenCo  $i$  located at bus  $i$ :

- Source Bus  $i$  and Sink Bus  $j$
- Max Bid Price:  $\rho_{ij}$  \$/MWh
- Max Bid Amount:  $FTR_{ij}^{Max}$  MW

FTRs can be acquired by market participants in the following ways:

#### 3.6.1 FTR Auction

The annual FTR auction is conducted by ISO to sell FTR quantities equivalent to a part of the total available transmission capacity. Subsequent auctions are held every month in which

FTR quantities equivalent to residual (after annual auction) transmission capacity are available to be sold. FTRs held by market participants (acquired during annual auction) can be entered into monthly auction as offers to sell. In PJM (2009) 50% of the total transmission capacity is available to be sold in the annual FTR auction. About 95% of the remaining 50% of the transmission capacity can then be sold in the subsequent monthly auctions. The auctions are generally held in multiple rounds where the FTRs bought in previous rounds can be entered as offers to sell in the current or subsequent rounds of auction.

### 3.6.2 FTR Secondary Market

Upon completion of the annual and monthly auctions, the market participants are allowed to buy/sell FTRs without entering into the monthly auctions. However, FTRs are point-to-point transmission contracts and because of the numerous combinations of pairs over which FTRs can be written, the liquidity of FTR trading over any given pair of grid buses is generally limited. To maintain the simultaneous feasibility of allocated FTRs, the ISOs impose following restrictions on the trading of FTRs in the secondary markets:

- FTR quantity and/or date can be reconfigured in case of change in ownership of Bilateral Contracts. However, such reconfiguration only entails transfer of rights and are approved only after credit worthiness of market participants is evidenced. The FTR cannot be reconfigured with respect to FTR receipt and withdrawal points.
- Any given FTR may be split into multiple FTRs, however, the receipt and withdrawal points cannot be altered compared to the original FTR. Additionally, the aggregate of the reconfigured FTRs must equal the original FTR in all respects.
- The dates specified in the reconfigured FTRs must not span less than 1 day.

### 3.6.3 Grand-fathered FTRs

ISOs allot a certain number of FTRs to be handed out for “free” to market participants based on historical firm-transmission<sup>3</sup> usage as well as for qualified transmission investments.

<sup>3</sup>Firm transmission is roughly defined as the actual transmission capacity minus the reservation capacity. The amount of firm-transmission is calculated differently by various ISOs.

The latter is generally thought to provide incentive for transmission investment. The FTRs allotted under this scheme are allowed to be sold through FTR auction or the secondary market. Unlike the FTR auction, allocation of FTRs is not based on market driven mechanism and can be done in the following ways:

*Direct Allocation:* In this method the ISOs allocate FTRs free of cost to the market participants. The rules for direct allocation of FTRs differ among various ISOs. The ISOs must ensure that the issued FTRs always satisfy the SFT. The effect of FTR allocation to either the generating companies or the load serving entities (LSEs) has a direct bearing on the level of market efficiency (will be discussed later).

*Auction Revenue Rights:* Auction Revenue Rights (ARRs) are financial instruments that entail their holders a share of proceeds from the annual FTR auction. ARRs, like the direct allocation method, are allocated to market participants on the basis of historical firm transmission usage. The firm historic usage of transmission system is determined differently by the ISOs. ARRs are specified in the same way as the FTRs and are settled based on the clearing prices from the annual FTR auction prices. ARRs can be of either obligation or option type. ARR obligations, just like FTR obligations, may entail their holders to benefits or liabilities, depending on the FTR auction outcome. In case of multi-round FTR auctions, the ARRs are settled using the average of annual FTR auction prices calculated in the different rounds. The ISOs must ensure the simultaneous feasibility of the allocated ARRs (just like FTRs).

The revenue from ARRs can be used by a market participant to buy any of the available FTRs and not just the FTRs specified along the same path as the ARRs. ARRs are thus, thought to be a better alternative to the direct allocation process.

### **3.7 Pricing of Transmission Congestion Derivatives and Partial Risk Hedging**

Siddiqui et al. (2003), using data from 2000 and 2001, show that the transmission congestion constraints (TCCs) in New York provide an effective hedge against uncertain prices. However, the prices paid for TCCs do not reflect congestion rents for large exposure hedges and over

large distances. The authors present two possible reasons for the market inefficiency causing customers to pay unreasonably high risk premiums. The first being low liquidity in TCC markets and the second being the relaxing of the requirement that the possible number of TCCs being equal to the actual energy flows.

Deng et al. (2005) present theoretical evidence for empirical findings that the clearing prices of FTRs, resulting from centralized auctions, significantly and systematically differ from the congestion revenue payoffs for holding those FTRs for the market participants. The authors first describe the mathematical optimization problem used by ISOs to issue FTRs to market participants.

$$\begin{aligned}
 & \max_{q_{ij}} \sum_{i,j \in m} \sum_{j \neq i} f_{ij} \cdot q_{ij} \\
 & \text{s.t. } q_i = \sum_{j \neq i} q_{ij} - \sum_{k \neq i} q_{ki} \forall i \in m \\
 & -L \leq G_r \cdot Q \leq L \forall r \in R \\
 & 0 \leq q_{ij} \leq \overline{q_{ij}} \forall i, j, \text{ and } j \neq i
 \end{aligned} \tag{3.6}$$

where  $q_{ij}, \forall i, j$  denote the FTR quantities from node  $i$  to  $j$ , and  $Q \equiv (q_1, q_2, \dots, q_m)^T$  denote the energy injection/withdrawal vector at the respective buses, imputed from all awarded FTRs. Let  $C \equiv (c_1, c_2, \dots, c_m)^T$  denote the vector of expected LMPs at the  $m$  nodes, then  $f_{ij} \equiv c_j - c_i$ .  $L$  is the vector of transmission line capacity limits and  $G_r$  is the power transfer distribution factor (PTDF) matrix for each contingency  $r \in R$ . The aggregate quantity of FTR awarded from node  $i$  to  $j$  is bounded above by  $\overline{q_{ij}}$ . Thus the objective is to maximize the auction value subject to nodal energy balance, transmission capacity and maximum possible FTR award constraints, respectively.

The authors show that even in presence of perfect foresight of payoff from holding FTRs (which entails bidding for FTRs at price equal to the expected present value of future congestion revenue payoff for a rational risk neutral participant), the clearing prices depend significantly on the amount of bid quantities. In particular, the limits on the FTRs quantities available to be purchased by market participants result in market clearing prices significantly different from bid prices. The authors use assumption of risk neutral participants, bidding FTR quantities at price equal to present value of expected future payoff, to construct a “virtual” energy auction



from the original annual FTR auction conducted by the ISO. Using simulations for a five-node grid, the authors run economic dispatch problem to obtain values for,  $P_i$ -, the ex-post nodal LMPs and  $Q$  - the vector of power dispatch level each generating unit. The quantity bid in the “virtual” energy auction (FTR auction) is then bounded above and below by  $\alpha Q$  and  $-\alpha Q$  respectively, and the bid price equals present value of expected future payoff. When  $\alpha = 1$ , the bid quantity in virtual energy auction equals the generator quantity amounts from economic dispatch problem and the payoff from holding FTRs matches exactly the market clearing prices. Hence, the generators are completely hedged against congestion risk. However, when  $\alpha \neq 1$ , the payoffs from holding FTRs significantly differ from market clearing prices and the generators are exposed to some price risk.

The result although trivial, shows a glaring problem with ISO’s conduct of FTR auctions. It is a common practice by ISO’s to limit the number of FTRs available in annual auctions to about 50% ( $\alpha = .5$ ) of the total transmission capacity. Hence, the generators cannot completely hedge against congestion risk and are exposed to significant financial risks because of the market design itself. About 95% of remaining transmission capacity is available to be purchased during subsequent monthly auctions. Whether the monthly auctions eliminate completely or partially the financial risks from congestion remains to be further analyzed.

*Locational vs Zonal Pricing:* In Benjamin (2010), Benjamin examines the risk-hedging properties of FTRs in markets where load is settled on a zonal level (such as PJM), rather than nodal level (MISO,NYISO,ISO-NE). In zonal pricing paradigm, where market participants pay/receive load weighted prices in a defined zone, the author shows, using a three-bus grid, that some market participants (depending on the location in the grid) may be over/under hedged against the price risks due to congestion.

### 3.8 FTRs and Market Power

Strategic behavior of FTR holders has been analyzed by various researchers. Joskow and Tirole (2000) study the effect of FTRs on market power of generators (GenCos). They conclude that for a specific configuration of GenCos (expensive monopolist at South node and price taking competitive GenCos at North node in a 2-node system) holding of FTRs by the

monopolist increases its market power. They also analyze different configurations of three-node networks and reach the same conclusion of market inefficiency caused by holding of FTRs. The claim was further established by Oren (1997) who shows that even in the absence of market concentration, expectation of congestion and passive transmission rights can lead to implicit collusion between generators and hence, market inefficiency. Stoft (1999), re-investigates Oren (1997) using Cournot competition based analysis to show that financial transmission rights such as TCCs can curb market power. Stoft points out that Oren's second example, which is intended to be a Cournot model, is mistakenly constructed as a Bertrand model and hence, is mis-analyzed. However, Stoft's analysis is based on long-term profits of strategic generators and not on the actual effect on prices (above marginal cost) that defines market power. Hogan Hogan (2000), using a slightly modified version of the grid used by Joskow et al, shows that use of FTRs does in fact increase social welfare. Sun (2005) shows that in the presence of stochastic parameter shocks, and absence of market power, acquisition of FTRs by risk averse market participants increases the social welfare compared with the case where there is no FTR available.

Unlike Physical Transmission Rights, FTRs cannot be used to withhold transmission capacity. However, by strategic bidding in the day-ahead market, an FTR owner may be able to increase congestion level in the transmission grid to earn higher payoff. The situation is presented by Bushnell (1999) and shows that although, this kind of strategic activity may not be indicative of market power abuse, but can deem lower efficiency levels compared to no FTR case.

### **3.8.1 Impacts of Allocation of FTRs on Market Efficiency**

Allocation of FTRs to the market participants has a direct bearing on market efficiency. Joskow and Tirole (2000) conclude that when the FTRs are allocated to a market participant that is neither a generator nor a load, the monopoly generator will want to acquire all the FTRs. When the FTRs are allocated to a market participant with no market power, the monopoly generator will buy no FTRs and when the FTRs are auctioned to the highest bidders, the generators will buy a random number of FTRs.

As shown by various researchers, FTRs provide incentives for GenCos to act strategically in order to increase their net-earnings. The FTRs can thus counter-act to the benefits of price risk hedging. In order to curb the potential of market power induced by FTRs, Bautista et al. (2004) proposed that the FTRs should be issued from- or to- a common point, determined by a measure called *relative cross-price sensitivity*. However, by effectively reducing the number of FTRs, it is not clear how the proposed approach will interfere with the price-risk hedging function of FTRs.

Benjamin (2010) examines the hedging and re-distributional properties of FTRs. Specifically, using two-bus and three-bus grids, the author shows how different allocation methods of FTRs have an impact on the distribution of congestion rent and the related implications for retail rates. It is shown that if the FTRs are allocated to LSEs (who are required to credit FTR revenues against electricity procurement costs), then in theory the retail customers can reap benefits of lower energy prices.

### 3.9 FTRs and Transmission Investment

The efficient functioning of electricity markets necessitates sufficient transmission capacity. Investment in transmission ensures that power consumed is generated using cheaper and/or alternative<sup>4</sup> sources of energy. Congestion on a grid, as indicated by separation of locational prices (although prices can differ for reasons other than congestion due to insufficient transmission capacity) leads to generation of power out-of-merit order and hence, reduced social surplus. The short-run congestion cost to society can be calculated as the difference in location prices times the energy transferred between two buses.

Investments in transmission capacities can be undertaken by centrally planned government regulations like in UK and Norway (see Woolf and Hunt) or through private enterprise. The latter approach requires provisioning of sufficient financial incentives facilitated by market mechanisms. A mixture of regulatory mechanism and merchant incentives is used for transmission investment in US and Australia.

The issuance of long-term or incremental FTRs (IFTRs) is considered to provide market

<sup>4</sup>Such as wind energy produced in the Dakotas.

based incentives for transmission investment, since the receivers of IFTRs receive payoffs that are determined using market based energy auctions. Under this design, additional FTRs are issued to market participants that invest in new transmission capacity. Currently, IFTRs are issued by CAISO, MISO and NYISO, while PJM and ISO-NE offer incremental ARRs. Bushnell and Stoft prove that the net value of IFTRs allocated under feasibility rules of existing transmission capacity, will not exceed the increase in social welfare. Also, if a transmission expansion causes reduction in social welfare, then the market participant holds IFTRs with negative value. Using a two-bus grid where a new transmission line is added, they show the negative impact on the payoff of existing FTRs, and propose that the investor be accountable for the negative externalities due to its transmission investment.

However, there are some difficulties in using this approach to incentivize transmission investment. The first problem is that the issued set of IFTRs, along with a base set of FTRs, must be simultaneously feasible over the existing transmission network. The base FTRs are issued periodically, i.e., yearly and monthly, are of shorter maturity periods. However, the IFTRs can have much longer maturity periods. Secondly, additional transmission investment over the years might mitigate LMP differentials over some paths of IFTRs and thus dilute the payoffs from holding those IFTRs. The investors must therefore, be aware and willing to take such risks.

As pointed out by Joskow and Tirole (2003), exerting of market power by some market participants can provide inaccurate estimation of benefits from transmission investment. Using a two-bus grid, they show that under a certain market setup, exerting of market power by a GenCo leads to over-reporting of congestion cost and hence, over-estimation of the benefits to be had from transmission investment. For another market setup, they also present the alternate example of under-estimation for benefits from transmission investment.

## CHAPTER 4. Study of Joint Bidding Strategies in Physical and Financial Electric Power Markets Using Analytical and Agent-Based Models

### 4.1 Introduction

Financial Transmission Rights (FTR) are in use in most of the US (restructured) wholesale electric power markets. FTRs were designed to provide market participants a financial tool that could be used to hedge against price volatility, due to congestion risks, in the Day-Ahead energy market (DAM) settlements. Fig. 4.1 shows a rough time-line of the operation of FTR auction and the day-ahead markets operated by the grid operator.

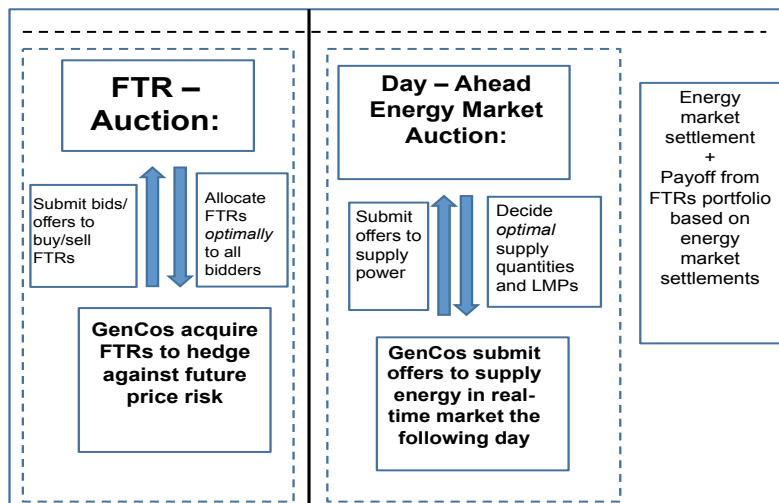

Figure 4.1 *Rough* time-line of restructured wholesale power markets

The payoff for holding an FTR from node  $k$  to  $m$  depends on the *locational marginal price* (LMP) differential between the two nodes in the said direction. The prices that energy traders are willing to pay to acquire FTR portfolios in the ISO FTR auctions will thus presumably

reflect their expectations with regard to payoffs in the DAM. On the other hand, after acquiring FTR portfolios, market participants can report strategic supply offers to the ISO in the day-ahead energy markets in an attempt to influence the LMP outcomes, upon which their FTR payments depend. The two problems have been studied by various researchers<sup>1</sup>, although in isolation i.e., in a partial-equilibrium like setup. Bidding in the FTR auction market is studied by taking as given the expected outcomes in the DA energy market, while the supply offer strategies in the DA energy market are modeled by assuming that a portfolio of FTRs has already been acquired. In essence, a feedback mechanism linking the bidding strategies in the two markets is yet to be studied extensively. We use a combination of analytical, and computational agent-based models to study this problem.

The original contribution of this paper is to develop a feedback mechanism between the two markets and to demonstrate the existence (or not) of pure-strategy Nash equilibria in the “bidding” strategies of market participants in the FTR auction, with respect to their expectations of energy market payoffs, as well as the expectations of their rivals’ “bidding” strategies in the two markets. A theoretical framework is first developed to establish the dynamics between the two markets and then, a three-bus grid is used to analytically study the dependence of “bidding” strategies in the two markets. A key finding of this research is that the supply-offer “bidding” behavior of market participants in the energy market is affected by the portfolios of FTRs they hold. In particular, we find the existence of pure-strategy Nash equilibria in supply offer “bidding” in the energy markets for only certain portfolios of FTRs.

We then use an agent-based computational model to study the dependence of bidding strategies of participants in the two markets. The market participants are modeled as adaptive learners that interact with other participants repeatedly in both the markets. We show that the market participants are able to systematically coordinate their bidding strategies in the two markets. In reporting the jointly-optimal bidding strategies the market participants are also able to identify any spatial advantages they might have. The organization of this chapter is as follows: In section 2, theoretical framework is developed to study the dynamics between

<sup>1</sup>The effects of FTRs on market power exercised by GenCos in DA energy market and overall market efficiency have been studied in Joskow and Tirole (2000), Oren (1997), Stoft (1999), Hogan (2000), Sun (2005)

the two markets. In section 4, a three-bus grid is used to analytically study the dependence of bidding strategies in the two markets. In section 5, we present an agent-based model to study the joint-bidding strategies of market participants in the two markets. Section 6 presents concluding remarks.

## 4.2 Dependence of GenCo Bidding Strategy in Day Ahead Market and FTR Auction

In this section an analytical framework is developed to examine the feedback mechanism that link the bidding strategies in two markets. In particular, the bid strategies of the GenCos in the FTR auction are conditioned on their expectations of DAM payoffs as well as on their expectations of rivals' strategies in the two markets. The dynamic choice problem for the GenCos is modeled analytically as a three stage process. In stage 1, day  $D = 0$ , the GenCos submit bids to acquire FTRs from the ISO's FTR auction. In stage 2, day  $D > 0$ , the GenCos report supply offers to the ISO for the DAM for dispatch for power production on day  $D+1$ . On day  $D+1$ , the GenCos receive (or are liable to pay) compensation for the FTRs acquired on day  $D = 0$  based on the LMP outcomes for day  $D+1$ . The GenCo bidding strategies for both markets are modeled as two-level optimization problems as presented in Fig. 4.

- Stage 2: In the first level of the two-level problem, the ISO solves an Optimal Power Flow (OPF) problem, while taking as given the supply offers by different GenCos. In the second level, the GenCos optimize supply function parameters  $b_i$  for  $i = 1, \dots, I$  to maximize profits from selling power as well as payoffs from holding a portfolio of FTRs  $F_i$  acquired on day  $D-1$ , while taking as given the dispatch quantities  $p_{Gi}$  and nodal prices  $LMP_{ki}$  determined in the first level by the ISO. Here,  $R_i$  is the vector of LMP differentials for portfolio of FTRs held by GenCos. It is assumed that the ISO's OPF solution process is transparent to each player. The *supply function equilibrium* problem yields best response functions  $b_i^r$  for each GenCo. In case, a pure strategy Nash equilibrium (or a set of equilibria), the optimal strategies can be obtained by simultaneously solving the best response functions.

- Stage 1: In the first level of the two-level problem, the ISO maximizes FTR auction revenue subject to Simultaneous Feasibility Test (SFT), which ensures that the allotted FTRs are feasible given then transmission constraints and contingency events. The ISO optimization problem (if solution exists) yields FTR clearing prices  $FCP_i$  and the allotted FTRs  $F_i$  (a pair of vectors for each GenCo  $i$ ). In the second level, the GenCos bid strategically a pair of vectors  $(F_i^b, \rho_i)$  that represent the maximum amounts of desired FTRs and the maximum willingness to pay for each FTR, respectively, to maximize the utility from owning FTRs. The value function derived by solving day D problem first is assumed to be known to each GenCo.

#### 4.2.1 Model Basics

Table 4.1 Admissible Exogenous Variables And Functional Forms

Variable	Description	Admissibility Restrictions
K	Total number of transmission grid buses	$K > 0$
N	Total number of physically distinct network branches	$N > 0$
J	Total number of LSEs	$J > 0$
I	Total number of GenCos	$I > 0$
$J_k$	Set of LSEs located at bus $k$	$\text{Card}(\cup_{k=1}^K J_k) = J$
$I_k$	Set of GenCos located at bus $k$	$\text{Card}(\cup_{k=1}^K I_k) = I$
$km$	Branch connecting buses $k$ and $m$ (if one exists)	$k \neq m$
BR	Set of all physically distinct branches $km, k < m$	$\text{BR} \neq \emptyset$
$x_{km}$	Reactance (ohm) for branch $km$	$x_{km} = x_{mk} > 0, km \in \text{BR}$
$P_{km}^U$	Thermal limit (MW) for real power flow on $km$	$P_{km}^U > 0, km \in \text{BR}$
$c_j, d_j$	Demand coefficients (\$/MW, \$/MW <sup>2</sup> ) for LSE <sub><math>j</math></sub>	$c_j, d_j > 0$
$\text{Cap}_i^L$	Lower real power operating capacity limit (MW) for GenCo <sub><math>i</math></sub>	$\text{Cap}_i^L \geq 0$
$\text{Cap}_i^U$	Upper real power operating capacity limit (MW) for GenCo <sub><math>i</math></sub>	$\text{Cap}_i^U \geq 0$
$a_i^0, b_i^0$	True cost coefficients (\$/MW, \$/MW <sup>2</sup> ) for GenCo <sub><math>i</math></sub>	$b_i^0 > 0$
$\text{MC}_i(p)$	$\text{MC}_i(p) = a_i^0 + 2b_i^0 p = \text{GenCo}_i$ 's true MC function for real power $p$	$\text{MC}_i(\text{Cap}_i^L) > 0$
$\text{FC}_{km}^{i,base}$	Base case FTR on path $km$ held by GenCo $i$	$\text{FC}_{km}^{i,base} = 0$

Table 4.2 Endogenous Variables

Variable	Description
$b_i$	Cost coefficient (\$/MW <sup>2</sup> ) reported by GenCo <sub><math>i</math></sub> $i=1, \dots, I$
$p_{Gi}$	Real-power generation (MW) supplied by GenCo <sub><math>i</math></sub> $i=1, \dots, I$
$P_{km}$	Real power (MW) flowing in branch $km \in \text{BR}$
$\text{LMP}_k$	Locational marginal price (\$/MW) at bus $k=1, \dots, K$
$\text{FCP}_{km}$	FTR clearing price for branch $km \in \text{BR}$
$F_{km}^i$	$F_{km}$ (MW) cleared in ISO FTR-auction for branch $km$ to GenCo <sub><math>i</math></sub>
$F_i$	FTR portfolio cleared in ISO FTR-auction to GenCo <sub><math>i</math></sub> for $\forall km \in \text{BR}$
$F_{km}^{ib}$	$F_{km}$ (MW) bid by GenCo <sub><math>i</math></sub> - Max amount of $F_{km}$ GenCo willing to buy
$F_i^b$	Vector of $F_{km} \forall km \in \text{BR}$ bid (to buy) by GenCo <sub><math>i</math></sub>



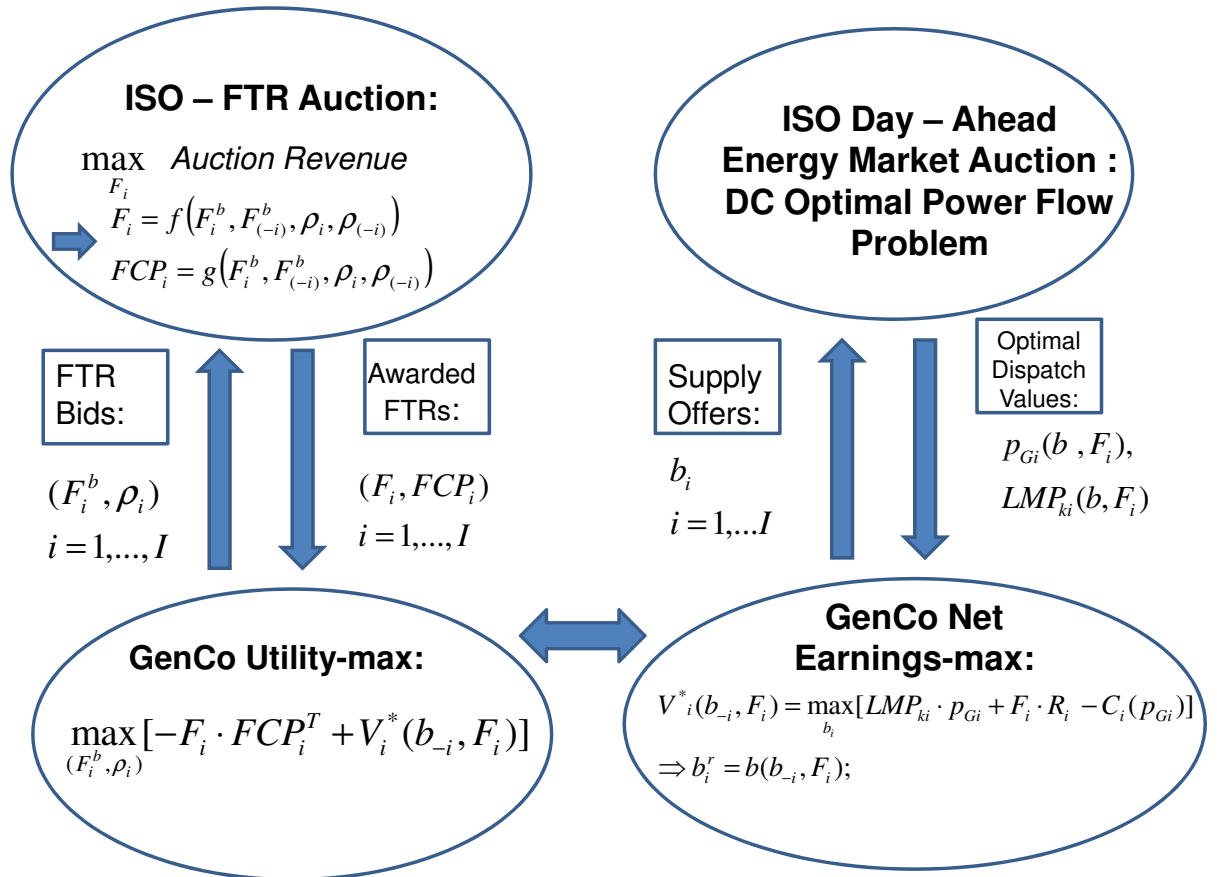

Figure 4.2 FTR Auction - Day Ahead Market Feedback Mechanism

We use a linear inverse demand function for electricity demand given by:

$$D_j(p_{Lj}) = c_j - 2d_j \cdot p_{Lj} \quad j = 1, 2, \dots, J \quad (4.1)$$

where  $p_{Lj}$  is the amount of load demanded by a Load Serving Entity (LSE)  $j$ , while  $c_j$  and  $d_j$  are positive demand function coefficients. Each GenCo has a quadratic cost function given by:

$$C_i(p_{Gi}) = a_i^0 \cdot p_{Gi} + b_i^0 \cdot p_{Gi}^2 \quad i = 1, 2, \dots, I \quad (4.2)$$

where  $a_i^0$  and  $b_i^0$  are non-negative true cost function coefficients. Thus, the supply offer (marginal cost function) submitted by the GenCos to the ISO takes a linear form given by:

$$MC_i(p_{Gi}) = a_i + 2b_i \cdot p_{Gi} \quad i = 1, 2, \dots, I \quad (4.3)$$

where  $a_i$  and  $b_i$  represent *reported* marginal cost function coefficients and hence, the marginal cost function reported by a GenCo to the ISO may differ from the true marginal cost. Next we describe the DC-Optimal Power Flow (DC-OPF) solved by ISO to determine the dispatch schedule of power generators.

#### 4.2.2 ISO Day-Ahead Market Optimal Power Flow Problem

A commonly used representation for a DC-OPF problem is to minimize total net costs corresponding to (TNC) subject to various transmission constraints. As explained at length in Sun and Tesfation (2007) the DC-OPF problem formulation is as follows, where all endogenous and exogenous variables are defined as in Tables ( 4.2) and ( ??), respectively:

$$\min_{p_{Gi}, p_{Lj}, \delta_k} \sum_{j=1}^J (c_j \cdot p_{Lj} - d_j \cdot p_{Lj}^2) - \sum_{i=1}^I (a_i \cdot p_{Gi} + b_i \cdot p_{Gi}^2) + \pi \left[ \sum_{km \in BR} [\delta_k - \delta_m]^2 \right] \quad (4.4)$$

subject to:

$$\sum_{i \in I_k} p_{Gi} - \sum_{i \in J_k} p_{Lj} - \sum_{km \in BR} P_{km} = 0; \quad \forall \text{ nodes } k, m = 1, \dots, K \quad (4.5)$$

$$P_{km} = B_{km}[\delta_k - \delta_m] \quad (4.6)$$

$$|P_{km}| \leq P_{km}^U \quad (4.7)$$

$$Cap_i^L \leq p_{Gi} \leq Cap_i^U \quad (4.8)$$

$$\delta_1 = 0 \quad (4.9)$$

where, (5) represents the nodal real power balance constraint. Real power thermal constraint for each branch  $km \in BR$  are represented in (7), constraints (8) are the real power operating capacity constraints for each GenCo  $i = 1, \dots, I$ .

The dispatch schedule (if a solution exists for the optimization problem) for each GenCo is determined as the primal variable of the optimization problem. Specifically, the LMPs are determined as functions of GenCo reported cost function parameters, apart from the exogenous variables that define transmission grid constraints.

$$p_{Gi}(\mathbf{a}, \mathbf{b}) = \varphi_{Gi}(a_i, \mathbf{a}_{-i}, b_i, \mathbf{b}_{-i}) \quad \forall \text{ GenCos } i = 1, \dots, I \quad (4.10)$$

The shadow prices (dual variables of OPF solution) associated with these constraints are the LMPs for the corresponding nodes. Just like the dispatch quantities, the LMPs are determined as functions of the GenCo reported cost function parameters:

$$LMP_k(\mathbf{a}, \mathbf{b}) = \phi_k(a_i, \mathbf{a}_{-i}, b_i, \mathbf{b}_{-i}) \quad \forall \text{ buses } k = 1, \dots, K \quad (4.11)$$

### 4.2.3 GenCo Day-Ahead Market Supply Choice Problem

Now we briefly describe a GenCo's decision making process. Upon observing ISO's OPF solution, the GenCos optimize the supply function slope to maximize profits, which includes the payoff from holding the portfolio of FTRs acquired earlier.

$$\max_{b_i} [[LMP_{k(i)}(\mathbf{a}, \mathbf{b}) * p_{Gi}(\mathbf{a}, \mathbf{b}) - C_i(p_{Gi}(\mathbf{a}, \mathbf{b}))] + \sum_{km} F_{km}^{i*} * R_{km}(\mathbf{a}, \mathbf{b})] \quad (4.12)$$

subject to:

$$LMP_{k(i)}(\mathbf{a}, \mathbf{b}) = \phi_{k(i)}(a_i, \mathbf{a}_{-i}, b_i, \mathbf{b}_{-i}) \quad (4.13)$$

$$p_{Gi}(\mathbf{a}, \mathbf{b}) = \varphi_{Gi}(a_i, \mathbf{a}_{-i}, b_i, \mathbf{b}_{-i}) \quad (4.14)$$

$$R_{km}(\mathbf{a}, \mathbf{b}) = LMP_m(\mathbf{a}, \mathbf{b}) - LMP_k(\mathbf{a}, \mathbf{b}) \quad (4.15)$$

for all GenCos  $i = 1, \dots, I$  and all nodes  $k, m = 1, \dots, K$  and  $k \neq m$ . The functions  $LMP_{k(i)} = \phi_{k(i)}(a_1, \dots, a_2; b_1, \dots, b_I)$  and  $p_{Gi} = \varphi_{Gi}(a_1, \dots, a_2; b_1, \dots, b_I)$  result from ISO's OPF solution as described above. The vector representing portfolio of FTRs held by a GenCo  $i$  is  $F_i^* = [F_{km}^{i*}]$ ,

which results from FTR-auction optimization problem run by ISO on day  $D - 1$  and is taken as given.  $R_{km}$  represents the compensation (liability) from holding an  $F_{km}$ . The result of GenCo optimization problem is a set of optimal response functions for GenCo  $i$ :

$$a_i^r = a_i(\mathbf{a}_{-i}, \mathbf{b}_{-i}, F_i^*) \quad (4.16)$$

$$b_i^r = b_i(\mathbf{a}_{-i}, \mathbf{b}_{-i}, F_i^*) \quad (4.17)$$

Now, assuming that pure strategy Nash equilibrium (or a set of equilibria) exists, so that for each GenCo we can derive optimal strategy pair  $(a_i^*, b_i^*)$ , the maximized objective function (value function) can then be represented as,

$$\mathbf{V}_i^*(\mathbf{a}^*, \mathbf{b}^*, F_i^*) \equiv \mathbf{V}_i^*(p_{Gi}(\mathbf{a}^*, \mathbf{b}^*), LMP_{k(i)}(\mathbf{a}^*, \mathbf{b}^*), F_i^*) \quad (4.18)$$

#### 4.2.4 ISO FTR Auction Formulation

FTRs are acquired by market participants through ISO's FTR auctions - annual and monthly - and through a secondary market. In this section we describe the optimization problem ISO solves in order to decide how to issue FTRs. An FTR bid by a market participant includes the following parameters: source (point of injection)<sup>2</sup> and sink (point of withdrawal) nodes  $k, m = 1, 2, \dots, K$  and  $k \neq m$ ; MW amount representing maximum number of an FTR a bidder is willing to purchase<sup>3</sup> -  $F_{km}^b$ ; and a dollar value representing maximum willingness to pay for ONE MW of the desired FTR -  $\rho_{km}$  (\$/MW). For all nodes  $k, m = 1, 2, \dots, K$  and  $k \neq m$  we define the set of available FTRs as  $\Theta(K)$ . Without loss of generality, we assume that only GenCos purchase FTRs and submit bids,  $(F_i^b, \rho_i)$ , where  $F_i^b$  represents column vector of maximum amounts of FTRs (for some ordered pairs  $\{k, m\} | F_{km} \in \Theta(K)$ ) a GenCo  $i$  is willing to purchase and  $\rho_i$  represents the column vector of bid prices for the corresponding FTRs.

*Revenue Adequacy and Simultaneous Feasibility Test (SFT)*: A central issue in the provisioning of FTRs by an ISO is revenue adequacy, which means that the congestion rent collection (in day-ahead market) must be greater than or equal to the total FTR target payment. Additionally, the set of issued FTRs must satisfy simultaneous feasibility test, which can be stated

<sup>2</sup>Injection and withdrawal do not imply *physical* trade of electricity.

<sup>3</sup>ONE unit of  $F_{km}$  held by a market participant entitles it to compensation (liability) owing to ONE MW of power transaction over the path  $k \rightarrow m$ . Also, there need not be a direct physical connection between the two nodes.

as following: the physical equivalent, in terms of nodal injections and withdrawals, of each possible combination of individual FTRs must result in feasible power flow conditions for each possible topological (n-1 contingency) scenarios of the network. As demonstrated in Sarkar and Khaparde (2008) and Hogan (1992a), revenue adequacy is guaranteed if the issued set of FTRs satisfy SFT. Each time there is a change in the configuration of FTRs, the SFT must be run to ensure that the transmission system can support the set of issued FTRs.

The objective of the auction for the ISO is to award the FTRs to those who value them the most. The auction value is maximized while respecting the transmission constraints on the system, which is ensured by running the SFT. The ISO FTR auction is formulated here as a linear programming problem, so that all constraints are linearized.

$$\max_{F_i} \sum_{i=1}^I \rho_i^T \cdot F_i \quad (4.19)$$

subject to:

$$\sum_{i=1}^I \beta \cdot (F_i + F_i^{base}) \leq P^U \quad (4.20)$$

$$F_i \leq F_i^b \quad i=1,2,\dots,I \quad (4.21)$$

Here  $F_i = M_i \cdot F$ , where  $F$  is column vector of all possible FTRs, i.e.  $\Theta(K)$ .  $M_i$  is a diagonal matrix (for GenCo  $i$ ) mapping the FTRs in  $F$  to the decision vector  $F_i$ .

$$M_i = \text{diag} \left[ I(F_{km}^{ib}) \right] \quad (4.22)$$

$$I(F_{km}^{ib}) = \begin{cases} 1, & \text{if } F_{km}^{ib} > 0 \\ 0, & \text{otherwise} \end{cases}$$

$F_i^{base}$  represents the *exogenously* given column vector of *base* FTRs,  $F_{km}^{i,base}$  already held by a GenCo  $i$ . As was mentioned in section 2 above, FTRs can be acquired in the auction held annually or in the subsequent monthly auctions. In case of annual FTR auction  $F_{km}^{i,base} = 0$  for all  $km \in BR$  and for all  $i$ , whereas for the monthly auctions the *base* FTRs maybe be positive for some paths  $km \in BR$ . Again, we have assumed that the FTR auction in the problem is the annual auction and hence, all the *base* FTRs are set to zero.  $\beta$  represents matrix of PTDF<sup>4</sup>  $\beta_{km}^t$

<sup>4</sup>Power Transmission Distribution Factor describes the amount of power transmitted through branch  $t$  due to FTR from node  $k$  to  $m$ . In other words  $\beta_{km}^t$  describes the equivalent amount of power transmitted through branch  $t$  due to 1 MW injection of power by GenCo  $i$  at bus  $k$  and to be withdrawn at bus  $m$ .

for all branches  $t \equiv km^5 \in BR$  due to FTRs  $F_{km}$  and  $P^U$  is the column vector of transmission line (heat) limits. Constraint ( ) represents conditions ensuring SFT and constraints (21) restrict the amount of FTRs issued to be less than the maximum amount willing to be purchased by a GenCo. The Lagrangian for the optimization problem is setup as follows

$$\Lambda = \sum_{i=1}^I \rho_i^T \cdot F_i + \mu^T \left( P^U - \sum_{i=1}^I \beta \cdot (F_i + F_i^{base}) \right) + \alpha_1^T (F_1^b - F_1) + \dots + \alpha_I^T (F_I^b - F_I) \quad (4.23)$$

The primal problem results in (if a solution exists for the optimization problem) optimal FTR allocations  $F_i^*$  for all GenCos  $i = 1, \dots, I$ . As mentioned earlier, not all FTR bids by GenCos are cleared to the maximum desired levels or even not at all in some cases. The FTRs represent virtual physical rights over the transmission capacity and hence, the supply limit of the FTRs is determined by the available transmission capacity. In case some transmission line thermal limits are reached because of the implied branch flows from allocated FTRs, the Lagrangian multipliers for such lines are non-negative. The Lagrangian multipliers of constrained transmission lines are then used to derive the FTR clearing prices (FCP). FCPs for cleared FTRs are the same for a given branch, irrespective of which GenCo is allocated the right. The following formula is used to price the cleared FTRs.

$$FCP_{km} = \frac{\partial \Lambda^*}{\partial F_{km}^{i,base}} = \sum_{t \in BR} \mu_t \cdot \beta_{km}^t \quad (4.24)$$

where,  $F_{km}^{i,base}$  is the *base case* FTR for some path  $km$  such that, FTR  $F_{km}^{i*} \leq F_{km}^{ib}$  for some GenCos  $i = 1, \dots, I$ , i.e. only *marginal* FTRs ( $F_{km}^{i*}$  not cleared up to the maximum desired amount  $F_{km}^{ib}$ ). The FTR clearing price for an FTR on branch  $km$  can be interpreted as the system cost of providing an extra unit of  $F_{km}$ , which can be derived by valuing the effect of additional MW injection at node  $k$  (withdrawal at node  $m$ ) on all capacity constrained transmission lines. The following properties for FCPs always hold true:

**P1.** The FCP of a *marginal* FTR is always equal to the bid price.

**P2.** The FCP of an FTR cleared fully is less than the bid price.

<sup>5</sup>The inconvenient notation is regretted. It must be noted that both  $t$  and  $km$  refer to branches, while  $km$  is also used to reference FTRs. The FTRs are essentially written over branches, but the physical equivalent of branch power flows implied by an  $FTR_{km}$  are imputed using the PTDFs. Hence, the distinction must be made between the superscript (branch) and subscript (FTR) when referencing PTDFs.

**P3.** The FCP of non-marginal FTR can be expressed as a function of FCPs of the marginal FTRs.

The proofs for these properties can be shown by simple algebraic rearrangement of the first order necessary conditions of the optimization problem.

#### 4.2.5 GenCo FTR Choice Problem

The result from the GenCo maximization problem is then considered as a value function,  $\mathbf{V}_i^*(\mathbf{a}^*, \mathbf{b}^*, F_i^*)$ , for the utility maximization problem of bidding for the optimal portfolio of FTRs.

$$\max_{F_i^b, \rho_i} \left[ -F_i^*(F_i^b, \rho_i, \mathbf{F}_{-i}^b, \rho_{-i}^T) \cdot FCP_i(F_i^b, \rho_i, \mathbf{F}_{-i}^b, \rho_{-i}^T) + \mathbf{V}_i^*(\mathbf{a}^*, \mathbf{b}^*, F_i^*) \right] \quad (4.25)$$

where all the variables are as explained earlier. Just like the DA market optimal supply choice problem, it is assumed that the ISO's FTR allocation problem is transparent to the GenCos. The GenCos then submit bids to purchase FTRs in order to maximize their net revenues from holding FTRs, dependant on expected choice of their, as well as that of rivals', supply offers in the DA energy market. It is assumed that the GenCos have all information regarding their own supply offer<sup>6</sup> and the rivals' optimal responses to their strategies.

### 4.3 Three Bus Grid: Analytical Model

In section 3 above we presented a theoretical framework within which to study the bidding behavior of GenCos in the two inter-related markets. Here we use a simplified three-bus grid (fig. A.1) example to establish an information feedback mechanism between the two markets.

#### 4.3.1 Day $D$ Energy Market

We first solve for day  $D$  energy market economic dispatch solutions (solved using ISO's OPF problem), and the optimal GenCo strategies for submitting supply offers. By the process

<sup>6</sup>In essence we assume that GenCos have all information about the expected demand and other conditions affecting supply offer choices in the DA market.

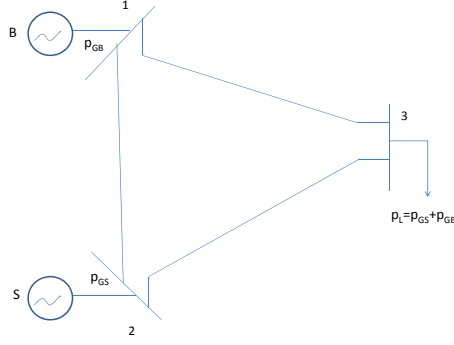

Figure 4.3 Three Node Grid

of backward induction, we then use the needed results to solve day the  $D - 1$  FTR-auction problem. In appendix B we solve the dispatch quantities for GenCos submitting supply offers into the DA energy market auctions for a three-bus grid by solving for optimal branch flows that complied with the given transmission constraints. In this section we derive the dispatch quantities by solving the ISO's Optimal Power Flow problem by maximizing net social benefit in the presence of transmission and other constraints. It is assumed that the load demand is high enough so that transmission line  $1 \rightarrow 3$  is congested. Also, it is assumed that there are no generation constraints and that the cost functions are same for the GenCos. The ISO's OPF problem<sup>7</sup> is formulated as follows:

$$\max_{P_{G1}, P_{G2}, P_L} (c \cdot p_L - d \cdot p_L^2) - \sum_{i=1,2} (a_i^0 \cdot p_{G_i} + b_i \cdot p_{G_i}^2)$$

subject to.

$$p_{G1} + p_{G2} = p_L$$

$$\beta_1 \cdot p_{G1} + \beta_2 \cdot p_{G2} = P_{13}^U \quad (4.26)$$

where  $\beta_1 \equiv \beta_{13}^1$ ,  $\beta_2 \equiv \beta_{23}^2$  are the PTDFs for injection of 1MW power by GenCos 1 and 2 on line  $1 \rightarrow 3$  respectively. The Lagrangian formulation for the OPF problem is the following.

$$H = (c \cdot p_L - d \cdot p_L^2) - \sum_{i=1,2} (a_i^0 \cdot p_{G_i} + b_i \cdot p_{G_i}^2) + \lambda(p_{G1} + p_{G2} - p_L) + \mu(P_{13}^U - \beta_1 \cdot p_{G1} - \beta_2 \cdot p_{G2}) \quad (4.27)$$

<sup>7</sup>The following reduced form OPF problem is as detailed in Liu et al. (2009). A similar formulation is also used by Liu and Wu (2007).



The first order necessary conditions for the OPF problem are the following.

$$p_{G1} : \quad -(a_1 + 2b_1 \cdot p_{G1}) + \lambda - \mu \cdot \beta_1 = 0 \quad (4.28)$$

$$p_{G2} : \quad -(a_2 + 2b_2 \cdot p_{G2}) + \lambda - \mu \cdot \beta_2 = 0 \quad (4.29)$$

$$p_L : \quad c - 2d \cdot p_L - \lambda = 0 \quad (4.30)$$

$$\lambda : \quad p_{G1} + p_{G2} - p_L = 0 \quad (4.31)$$

$$\mu : \quad P_{13}^U - \beta_1 \cdot p_{G1} - \beta_2 \cdot p_{G2} = 0 \quad (4.32)$$

Solving the OPF yields the following dispatch quantities for the two GenCos,

$$\begin{aligned} p_{G1} &= \frac{(c - a_1^0)\beta_2^2 - (c - a_2^0)\beta_1\beta_2 + 2d(\beta_1 - \beta_2)P_{13}^U + 2b_2\beta_1P_{13}^U}{2d(\beta_1^2 + \beta_2^2 - 2\beta_1\beta_2) + 2b_1\beta_2^2 + 2b_2\beta_1^2} \\ p_{G2} &= \frac{(c - a_2^0)\beta_1^2 - (c - a_1^0)\beta_1\beta_2 + 2d(\beta_2 - \beta_1)P_{13}^U + 2b_1\beta_2P_{13}^U}{2d(\beta_1^2 + \beta_2^2 - 2\beta_1\beta_2) + 2b_1\beta_2^2 + 2b_2\beta_1^2} \end{aligned} \quad (4.33)$$

Using the envelope theorem<sup>8</sup>, the following expressions for LMPs can be derived,

$$LMP_1 = \lambda^* - \mu^* \cdot \beta_1 \quad (4.34)$$

$$LMP_2 = \lambda^* - \mu^* \cdot \beta_2 \quad (4.35)$$

$$LMP_3 = \lambda^* \quad (4.36)$$

Given the dispatch levels and LMPs, the GenCos move simultaneously to choose supply functions to maximize profits from energy production as well as the payoff from FTR portfolio already acquired. For the ease of analysis, we assume that each GenCo is purely hedging its production revenues against congestion risks and hence, bids an FTR portfolio accordingly. In the three-node grid we have used in this paper, the power is injected by GenCos at their respective buses and withdrawn at the load bus. Hence, GenCos 1 and 2 hold FTRs  $F_{13}^{1*}$  and  $F_{23}^{2*}$  respectively. Using first-order conditions of GenCos' profit functions w.r.t the decision

<sup>8</sup>We can introduce an *exogenously* given load demand variable  $\xi_k = 0$  for each of the nodes and assume the regularity conditions hold to apply the implicit function theorem to derive these results.

variable  $b_i$ , we can derive the optimal response functions for each GenCo,

$$b_1^r = b_1^0 + \frac{d \cdot (\beta_2^2 + \beta_1^2 - 2\beta_1\beta_2)}{\beta_2^2} + b_2 \frac{\beta_1^2}{\beta_2^2} - \frac{2F_{13}^{1*} \cdot (2b_2^2\beta_1^4 + b_2 \cdot (4\beta_1^4d - 6\beta_1^3\beta_2d + 2\beta_1^2\beta_2^2d + b_1^0\beta_1^2\beta_2^2))}{\beta_2^4(c - a_1^0) + \beta_1\beta_2^3(a_2^0 - c) - 2P_{13}^U(\beta_2^3d - b_2\beta_1\beta_2^2 - \beta_1\beta_2^2d) + 2F_{13}^{1*}(b_2\beta_1^2\beta_2^2 + \beta_1^2\beta_2^2d - \beta_1\beta_2^3d)} + \frac{2F_{13}^{1*} \cdot (2\beta_1^4d^2 - 6\beta_1^3\beta_2d^2 + 6\beta_1^2\beta_2^2d^2 + b_1^0\beta_1^2\beta_2^2d - 2\beta_1\beta_2^3d^2 - b_1^0\beta_1\beta_2^3d)}{\beta_2^4(c - a_1^0) + \beta_1\beta_2^3(a_2^0 - c) - 2P_{13}^U(\beta_2^3d - b_2\beta_1\beta_2^2 - \beta_1\beta_2^2d) + 2F_{13}^{1*}(b_2\beta_1^2\beta_2^2 + \beta_1^2\beta_2^2d - \beta_1\beta_2^3d)} \quad (4.37)$$

$$b_2^r = b_2^0 + \frac{d \cdot (\beta_2^2 + \beta_1^2 - 2\beta_1\beta_2)}{\beta_1^2} + b_1 \frac{\beta_2^2}{\beta_1^2} - \frac{2F_{23}^{2*} \cdot (2b_1^2\beta_2^4 + b_1 \cdot (4\beta_2^4d - 6\beta_2^3\beta_1d + 2\beta_1^2\beta_2^2d + b_2^0\beta_2^2\beta_1^2))}{\beta_1^4(c - a_2^0) + \beta_2\beta_1^3(a_1^0 - c) - 2P_{13}^U(\beta_1^3d - b_1\beta_2\beta_1^2 - \beta_2\beta_1^2d) + 2F_{23}^{2*}(b_1\beta_2^2\beta_1^2 + \beta_2^2\beta_1^2d - \beta_2\beta_1^3d)} + \frac{2F_{23}^{2*} \cdot (2\beta_2^4d^2 - 6\beta_2^3\beta_1d^2 + 6\beta_2^2\beta_1^2d^2 + b_2^0\beta_2^2\beta_1^2d - 2\beta_2\beta_1^3d^2 - b_2^0\beta_2\beta_1^3d)}{\beta_1^4(c - a_2^0) + \beta_2\beta_1^3(a_1^0 - c) - 2P_{13}^U(\beta_1^3d - b_1\beta_2\beta_1^2 - \beta_2\beta_1^2d) + 2F_{23}^{2*}(b_1\beta_2^2\beta_1^2 + \beta_2^2\beta_1^2d - \beta_2\beta_1^3d)} \quad (4.38)$$

where,  $b_1^r = b_1(b_2, F_{13}^{1*})$  is the response function of GenCo 1, w.r.t the reported supply function coefficient of GenCo 2. At this point it is worth investigating whether pure strategy Nash equilibrium (or a set of equilibria) exists in the supply offer “bidding” strategy for the two GenCos.

#### *Effects of FTR Portfolios on Energy Supply Offers*

To investigate whether Nash equilibrium (or a set of equilibria) exists in the supply offer “bidding” strategy for the two GenCos, we assume the numerical values for the various demand and cost function parameters as in Liu and Wu (2007). The system inverse demand function is given as,

$$D_j(p_{Lj}) = 50 - 0.02 \cdot p_{Lj} \quad (4.39)$$

The generators' quadratic cost function is given as

$$C_i(p_{Gi}) = 2 \cdot p_{Gi} + .015 \cdot p_{Gi}^2 \quad (4.40)$$

Since FTRs are already acquired, we can also treat those as constants and assume numerical values based on the following feasibility constraint.

$$\beta_1 \cdot F_{13}^1 + \beta_2 \cdot F_{23}^2 \leq P_{13}^U \quad (4.41)$$

where  $\beta_1 = 0.5$ ,  $\beta_2 = 0.25$  and  $P_{13}^U = 300$  MW. By assuming that the FTRs acquired by the two GenCos are in certain ratios (while respecting the above constraint as an *equality*), we plot the resulting reaction functions to check for the existence of equilibria. Fig. 4.4 presents the cases for non-existence of pure-strategy Nash supply-function equilibria, while for the FTR portfolios shown in Fig. 4.5, pure-strategy Nash supply-function equilibria exist.

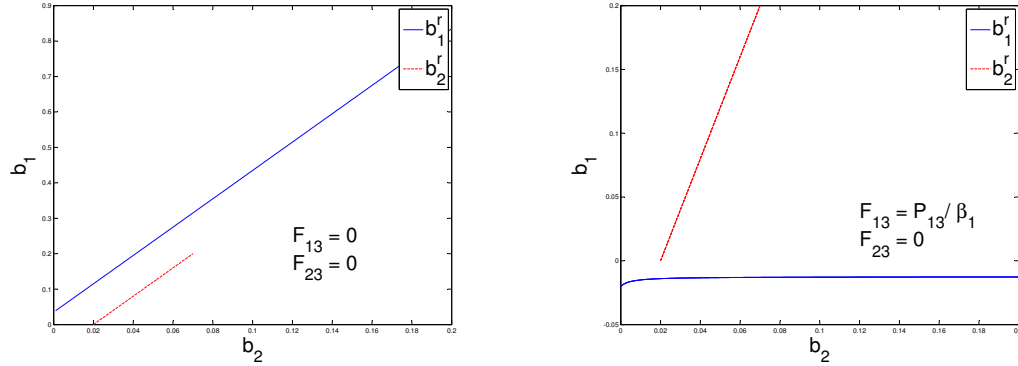

Figure 4.4 No Pure Strategy Nash-Supply Function Equilibria

The results for the case of no FTRs held by either firm are similar to the one derived by Liu and Wu (2007), i.e., no pure strategy supply-function equilibria exist. However, it is interesting to note that if the FTRs held by the two firms are in certain specific ratios, then there seems to exist unique equilibria in the strategy space of the supply offer slope coefficient. This reaffirms our conjecture that that the GenCo “bidding” strategy in the DA energy market must be affected by portfolio of FTRs already acquired. It is also interesting to note that GenCo 1’s optimal response is to submit negative slope coefficients, i.e.  $b_1^r < 0$ , for certain values of  $b_2$ . In effect, GenCo 1 submits a *downward sloping supply offer*<sup>9</sup> in response to GenCo 2’s supply offer (not necessarily optimal  $b_2$ ’s). Thus, it appears that GenCo 1 is willing to accept losses from the physical energy sales by bidding below the true marginal cost of operation  $b_1^0$ . By bidding strategically, the GenCo is creating/relieving congestion in the grid so as to maximize the total revenues from the sale of energy as well as payoff from holding FTRs.

<sup>9</sup>It should be strongly noted that, in reality, GenCos are **NOT** allowed to submit downward sloping supply offers. The ISO rearranges the blocks of supply offers submitted by GenCos in order to have upward sloping supply offers.

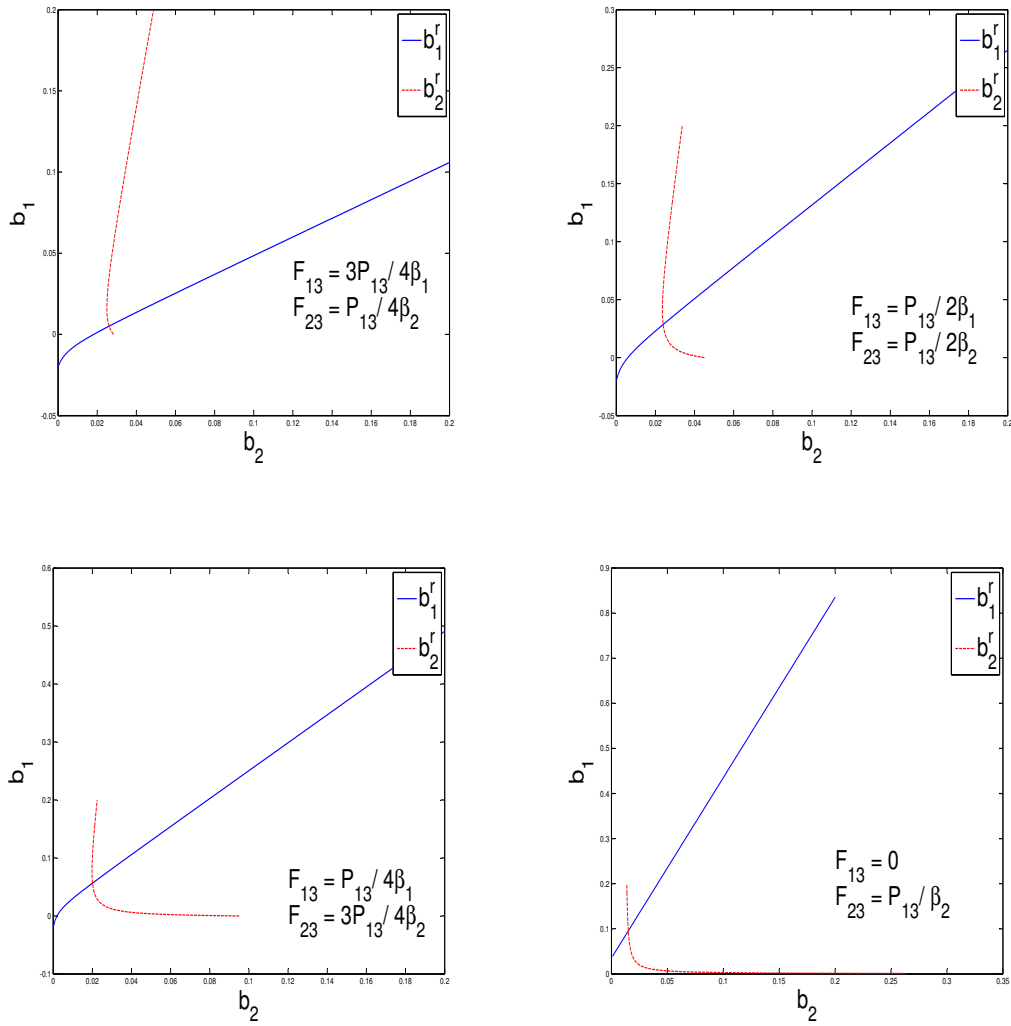

Figure 4.5 Pure Strategy Nash-Supply Function Equilibria

To illustrate this point, we will use the case where only GenCo 1 holds FTRs ,i.e.,

$$F_{13}^{1*} = \frac{P_{13}^U}{\beta_1}$$

$$F_{23}^{2*} = 0$$

and compare GenCo1's net-earnings, FTR revenues and energy sales revenues when submitting supply offers strategically against when it submits the true marginal cost function,

$$b_1^r = b_1^0 \quad \forall \quad b_2$$

The latter case will henceforth be referred to as the benchmark case. Also, GenCo 1's supply offer slope coefficient has been constrained to always be nonnegative, i.e.  $b_1^r \geq 0$ , so that it cannot submit negatively sloped "supply" function. However, as can be seen from Fig. 4.6(a), GenCo 1's optimal response to GenCo 2's supply offer  $b_2$  is to always bid below its true marginal cost slope coefficient.

From Fig. 4.6(d) below we can see that the net earnings of GenCo 1 are higher than the benchmark case even though,  $b_1^r = 0$  and much below the true slope coefficient  $b_1^0 = 0.015$ . Hence, as seen from Fig. 4.6(e) it is clear that GenCo 1 is losing money in energy sales, while being compensated due to higher FTR revenues, as shown in Fig. 4.6(f). The following equation should help make this point clearer. For notational convenience,  $(b_1, b_2)$  will be referred to as  $(\cdot)$ :

$$NetEarnings_1(\cdot) = \underbrace{LMP_1(\cdot) * p_{G1}(\cdot) - (a_1^0 * p_{G1}(\cdot) + b_1^0 * p_{G1}^2(\cdot))}_{\text{Energy sales revenue}} + \underbrace{(LMP_3(\cdot) - LMP_1(\cdot)) * F_{13}}_{\text{FTR revenue}} \quad (4.42)$$

By offering to supply at constant marginal cost, i.e  $b_1^r = 0$ , which is always less than GenCo 2's reported supply function slope parameter  $b_2$ , GenCo1 is dispatched at higher level as compared to the benchmark case (see Fig. 4.6(c)). However, to maintain the transmission constraint to hold at equality <sup>10</sup>, an additional 1 MW injection of power by GenCo 1 requires reduction in GenCo2 dispatch by 2 MW<sup>11</sup>. Hence, the aggregate system supply decreases (compared

<sup>10</sup>For the case of no transmission grid congestion, the payoffs from FTRs becomes zero, and hence is not of relevance to this analysis.

<sup>11</sup>The result derives from the grid configuration, i.e,  $\beta_{13}^1 = 2\beta_{13}^2$ , which causes the power flowing on line  $P_{13}^U$  due to injection at bus 1 to be twice of that due to power injected at bus 2.

to benchmark case) causing the price paid at load bus,  $LMP_3$  to increase. Hence, the LMP differential  $LMP_3 - LMP_1$  increases, which can be seen in Fig. 4.6(b) and the GenCo gains higher revenues from holding FTRs.

However, it must be noted that the dispatch amounts,  $p_{G1} < F_{13} \forall b_1^r$  (see Fig. 4.6(c)) and as seen from Eq(4.42) the drop-off from energy revenues, due to lower LMP at generation bus, is less than gain from FTR revenues because of higher LMP differential between the load bus and generation bus. The results might change substantially for lower amounts of  $F_{13}$  held by GenCo 1.

### 4.3.2 Day $D - 1$ FTR Auction

In the FTR auction each bidder intends to maximize its utility from holding FTRs after considering its own production decision in the next period as well as its opponent's bidding strategies in the present period, subject to the ISO's FTR market clearing results. The two-level optimization problem is similar to the economic dispatch problem presented above. In the first level, the ISO maximizes FTR auction revenue given the FTR bids and subject to transmission and other contingency constraints. GenCos 1 and 2 bid  $F_{13}^{1b}$  and  $F_{23}^{2b}$ , respectively. The ISO's auction revenue maximization problem is,

$$\begin{aligned} & \max_{F_{13}^1, F_{23}^2} \rho_{13}^1 \cdot F_{13}^1 + \rho_{23}^2 \cdot F_{23}^2 \\ & \text{subject to:} \\ & \beta_1 \cdot F_{13}^1 + \beta_2 \cdot F_{23}^2 \leq P_{13}^U \\ & 0 \leq F_{13}^1 \leq F_{13}^{1b} \\ & 0 \leq F_{23}^2 \leq F_{13}^{2b} \end{aligned} \quad (4.43)$$

The Lagrangian is presented below followed by the graphical solution (fig. 4.7) for the linear programming problem.

$$\Lambda = \rho_{13}^1 \cdot F_{13}^1 + \rho_{23}^2 \cdot F_{23}^2 + \mu_{13}[P_{13}^U - \beta_1 \cdot F_{13}^1 + \beta_2 \cdot F_{23}^2] + \alpha_1 \cdot [F_{13}^{1b} - F_{13}^1] + \alpha_2 \cdot [F_{23}^{2b} - F_{23}^2] \quad (4.44)$$

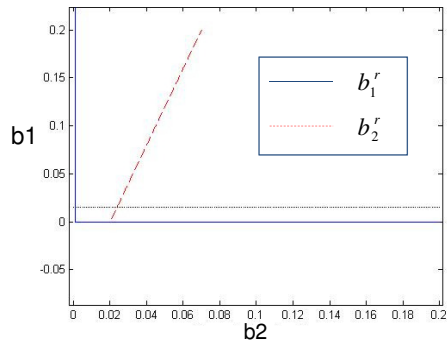

(a) Reaction Functions:  $b_1^r$  and  $b_2^r$

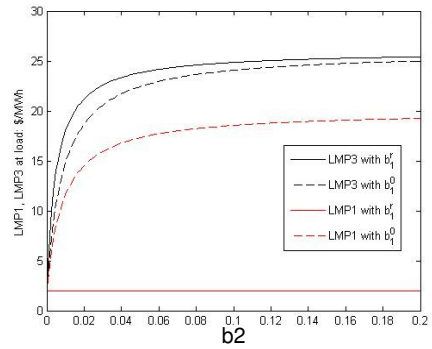

(b) LMPs:  $LMP_1$  and  $LMP_3$

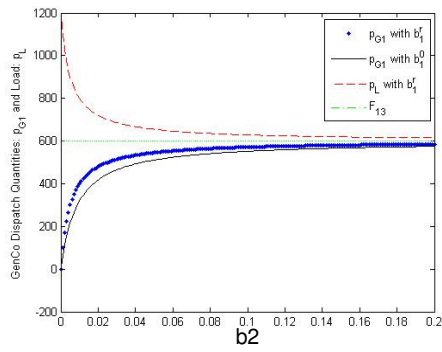

(c) Dispatch Amount:  $P_{G1}$  and FTR:  $F_{13}$

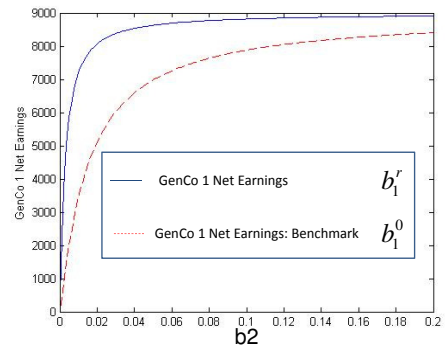

(d) Total Net Earnings

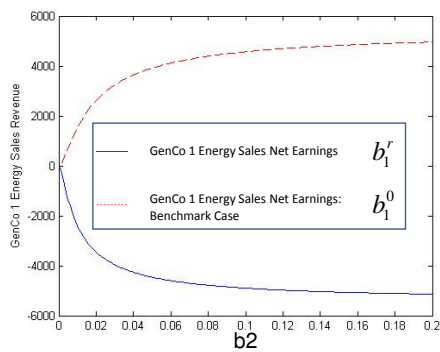

(e) Energy Sales Revenues

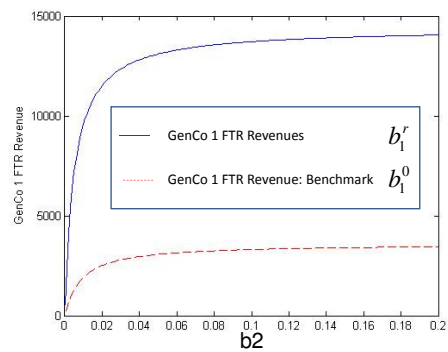

(f) FTR Revenues

Figure 4.6 GenCo 1 Dispatch, Net Earnings, FTR- and Energy-Sales Revenues

The first order necessary conditions are as following:

$$F_{13}^1 : \rho_{13}^1 - \mu_{13} \cdot \beta_1 - \alpha_1 = 0 \quad (4.45)$$

$$F_{23}^2 : \rho_{23}^2 - \mu_{13} \cdot \beta_2 - \alpha_2 = 0 \quad (4.46)$$

$$\mu_{13} : P_{13}^U - \beta_1 \cdot F_{13}^1 + \beta_2 \cdot F_{23}^2 \geq 0 \quad \perp \quad \mu \quad (4.47)$$

$$\alpha_1 : F_{13}^{1b} - F_{13}^1 \geq 0 \quad \perp \quad \alpha_1 \quad (4.48)$$

$$\alpha_2 : F_{23}^{2b} - F_{23}^2 \geq 0 \quad \perp \quad \alpha_2 \quad (4.49)$$

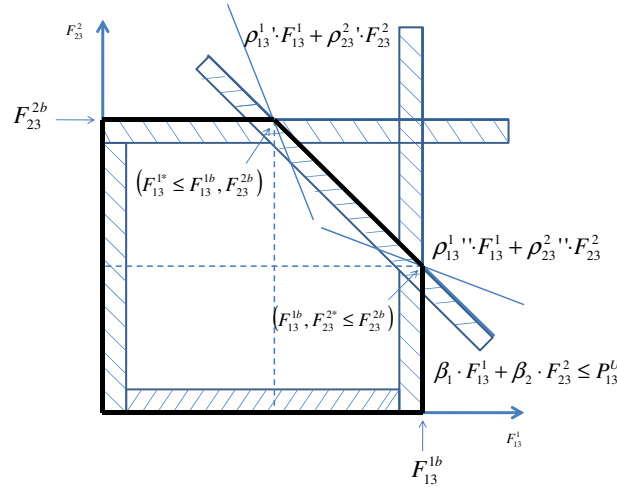

Figure 4.7 FTR Auction Graphical Solution

The graph shows the various constraints where the dashed boxes indicate the direction of feasible region. The feasible set of solutions is depicted using the thicker line. Finally, depending on the value of FTR bid price ratio,  $\left| \frac{\rho_{13}^1}{\rho_{23}^2} \right|$ , either of the two shown iso-revenue lines is feasible. Based on these fact, the results for the linear programming problem are summarized as follows.

Case 1:

$$\left| \frac{\rho_{13}^1}{\rho_{23}^2} \right| < \left| \frac{\beta_1}{\beta_2} \right| \implies \begin{cases} F_{13}^{1*} = F_{13}^{1b}, & \alpha_1 \geq 0 \\ F_{23}^{2*} < F_{23}^{2b}, & \alpha_2 = 0 \end{cases}$$



The resultant allocation of FTRs is as follows:

$$F_{13}^{1*} = F_{13}^{1b} \quad (4.50)$$

$$F_{23}^{2*} = \frac{P_{13}^U + \beta_1 F_{13}^{1b}}{\beta_2} \quad (4.51)$$

The FCPs for the awarded FTRs can be calculated using the formula in equation (24) and from the first order necessary conditions.

$$FCP_{13} = \mu_{13} \cdot \beta_1 = \rho_{13}^1 - \alpha_1 = \rho_{23}^2 \cdot \frac{\beta_1}{\beta_2} \quad (4.52)$$

$$FCP_{23} = \mu_{13} \cdot \beta_2 = \rho_{23}^2 \quad (4.53)$$

The results verify the properties 1-3 for FTR clearing prices presented in section 3.4 above. It can be seen that the  $FCP_{23}$  of the *marginal* FTR is equal to the bid price  $\rho_{23}$  and that the  $FCP_{13}$  of FTR cleared in full is less than bid price  $\rho_{13}$ . Also,  $FCP_{13}$  can be expressed a function of bid price  $\rho_{23}$  of the marginal FTR. Similarly, results are symmetric for the other case.

*Case 2:*

$$\left| \frac{\rho_{13}^1}{\rho_{23}^2} \right| > \left| \frac{\beta_1}{\beta_2} \right| \implies \begin{cases} F_{13}^{1*} < F_{13}^{1b}, & \alpha_1 = 0 \\ F_{23}^{2*} = F_{23}^{2b}, & \alpha_2 \geq 0 \end{cases}$$

The resultant allocation of FTRs is as follows:

$$F_{23}^{2*} = F_{23}^{2b} \quad (4.54)$$

$$F_{13}^{1*} = \frac{P_{13}^U + \beta_2 F_{23}^{2b}}{\beta_1} \quad (4.55)$$

The FTR clearing prices are as follows:

$$FCP_{23} = \mu_{13} \cdot \beta_2 = \rho_{23}^2 - \alpha_2 = \rho_{13}^1 \cdot \frac{\beta_2}{\beta_1} \quad (4.56)$$

$$FCP_{13} = \mu_{13} \cdot \beta_1 = \rho_{13}^1 \quad (4.57)$$

#### 4.4 Three-Bus Grid: Agent Based Model

As suggested by the discussion in previous sections, the study of risk management in wholesale power markets is complex, requiring detailed modeling and analysis of strategic decision

making by market participants, market operators, and oversight agencies. Analytical models are not able to sufficiently address the complexity of this decision making process. In this section we present an alternate approach that uses *reinforcement learning* (RL) to model the behavior of GenCos in the two markets. The model uses a two-tier matrix game approach to obtain the joint-optimal bidding strategies in the two markets, when the GenCos compete with each other to maximize the individual net-earnings.

A similar approach has been used by Babayigit et al. (2010) to study the same problem. However, their study differs from our work in two significant ways: 1) The form of objective function in ISO's FTR auction used in ) differs from the general form used by ISOs. We have used the more general form of objective function as seen in ISO-NE tutorial on FTR auctions), 2) The primary objective of their study was to validate the modeling method by comparing their results to the well established results from an earlier study by Joskow and Tirole. The authors were able to illustrate the existence of Nash equilibrium in supply offer strategies, given certain portfolios of FTR already acquired. They also show the effects of FTR portfolios on supply offer strategies, and the overall joint payoffs. However, the effect of "anticipated" supply offer strategies on FTR bidding strategies was not established.

In this paper, we establish the feedback mechanism in the bidding strategies of two markets. The results show that GenCos' FTR bidding strategies are affected by supply offer strategies based on the following factors: 1) Location on the grid, 2) Thermal limits on transmission lines. A description of the process is now presented.

#### 4.4.1 Two-Tier Matrix Game Approach

A two-tier matrix game approach was used to replicate the process of *backward induction*, used commonly in solving multi-stage game theoretic models. The upper tier matrix represents the FTR auction (Stage 1), and the bottom layer represents the day-ahead energy market. At each stage the GenCos can choose from a set of action choices. The process of obtaining joint bidding strategies, as depicted in Fig. 4.4.1, involves 2 players that select from  $N$  different FTR portfolios, and  $J = 2$ <sup>12</sup> supply offer choices. The process involves the following steps:

<sup>12</sup>The set of action strategies is arbitrarily chosen in order to ease the exposition of the two-tier game process.

1. In Stage 1,  $GenCo_i$ , for  $i = 1, 2$  selects FTR portfolio  $FTR_i^n$ , for  $n = 1..N$
2. In Stage 2, calculate the payoff matrix for different combinations of  $GenCo_i$  energy supply-offer strategies  $a_{ij}^n$ , for  $j = 1, 2$ , given  $FTR_i^n$
3. Use reinforcement (RI) learning to solve Stage 2 problem to obtain supply offer strategies that yield net earning,  $NE_i^n(a_{1j}^n, a_{2j}^n)$
4. Assign  $NE_i^n(a_{1j}^n, a_{2j}^n)$  as net earnings for the given FTR portfolio combination.
5. Use RI learning to solve Stage 1 problem to obtain the FTR portfolios.

The iterative method described above yields the joint bidding strategies for the GenCos and the overall joint payoff from the two markets. The biggest advantage of using this method is that it allows analysis to proceed even in cases where no pure-strategy Nash equilibria, in supply offer strategies, exist<sup>13</sup>.

#### 4.4.2 GenCo Action Set Selection

We will now describe the process used to setup action choices of GenCos in the two markets.

##### 4.4.2.1 Day-Ahead Market Action Choice Set

GenCo report their marginal production cost functions as supply offers in DA market, defined as  $C_i(p_{Gi}) = a_i^0 + 2b_i^0 p_{Gi}$ , for  $i = 1, 2, \dots, I$ , where  $a_i^0$  and  $b_i^0$  represent the ordinate and slope of *true* marginal cost. So, the supply offers *reported* GenCo  $i$ , consist of the pair  $(a_i^r, b_i^r)$ . The GenCos also report the pair  $(Cap^L, Cap^U)$  as lower and upper production capacities. However, we assume that the upper and lower capacities are fixed at the true levels. Additionally, to further simplify the model we use a single multiplier  $da_i$  to obtain the reported supply offer,  $da_i * (a_i^0, b_i^0)$ . Finally, the supply offer choice variable is allowed to be either (*high, true, low*),

<sup>13</sup>As shown in Nanduri and Das ), reinforcement learning algorithm can be used to derive pure-strategy equilibria. However, various researchers such as Wilson, Oren), have shown that existence of pure-strategy supply function equilibria cannot be guaranteed.

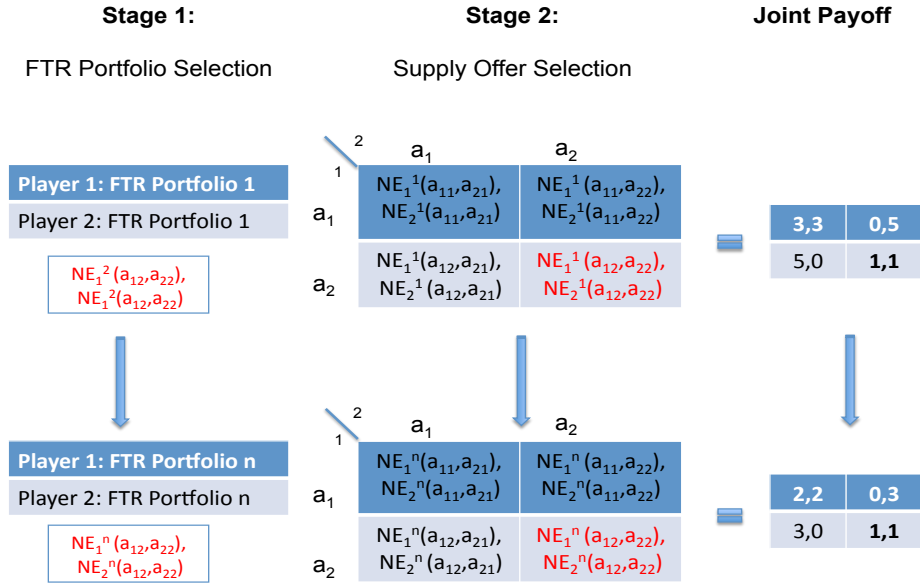

Figure 4.8 Two-Tier Matrix Game Approach for Joint-Optimal Bidding Strategies

i.e.,

$$da_i = \begin{cases} da_i^H, & \text{if } da_i > 1 \\ da_i^T, & \text{if } da_i = 1 \\ da_i^L, & \text{if } da_i < 1 \end{cases}$$

#### 4.4.2.2 FTR-Auction Action Choice Set

FTR auction demand bid parameters for GenCo  $i$  located at bus  $i$  are following:

- Source bus  $i$  and sink bus 3
- Maximum price willing to pay:  $\rho_{i3}$  \$/MW
- Maximum amount willing to buy:  $FTR_{i3}^{Max}$  MW

Like the DA market a single multiplier  $f_i$  is used to obtain the FTR demand bids  $f_i * (\rho_{i3}, FTR_{i3}^{Max})$  for the GenCos. The action choices in FTR auction are also allowed to be either of (*high, true, low*),

$$f_i = \begin{cases} f_i^H, & \text{if } f_i > 1 \\ f_i^T, & \text{if } f_i = 1 \\ f_i^L, & \text{if } f_i < 1 \end{cases}$$

The payoff from an FTR portfolio is settled from the *congestion rent* collected after the settlement of DA market. Hence, if all GenCos are risk neutral, the theory of *rational expectations* says that the FTR demand bid price and quantity reflect the expectations of GenCo's FTR payoffs (and hence, the congestion rent "owed" by them) after the settlement of DA market. "True" FTR demand bid parameters  $(\rho_{i3}, FTR_{i3}^{Max})$  are set so that, if all FTR demand bids are "true," and all DA energy supply offers are "true," then for all GenCos  $i = 1 \dots I$ ,

$$FTR \text{ Payment of GenCo } i = FTR \text{ Revenue (Congestion Rent) of GenCo } i$$

This condition implies that if all GenCos are truth telling in both the markets and bid for FTRs based on the expectations of DA market settlements, then the total amount paid by all GenCos to the ISO in the FTR auction equals the congestion rent collected (and hence, the FTR payoff they receive) in DA market. This condition also implies that GenCo  $i$  has fully hedged its congestion risk in the DA market.

Hence, given that the above conditions hold, Oren et al ) demonstrate the equivalence between FTR auction and DA market, and

$$FTR \text{ Auction Revenue} = \text{Congestion Rent in DA Market}$$

#### 4.4.3 Results

To see how the GenCos learn their bidding strategies in the two markets, the same three bus grid was used as in the analytical model presented above. Additionally, to study the effects of spatial location on a GenCo's bidding strategies, we imposed thermal limit on one transmission

line at a time. The action sets for the two GenCos were selected as reported earlier and the bidding strategies were obtained using the process described in section. The process was run 50 times.

*Case 1: Thermal Limit on Line 1 → 3*

The bidding strategies for the two GenCos, in FTR and DA markets, when thermal limit is imposed on line 1 → 3 are shown in Fig. 4.4.3. The end points of the blue vertical line represent bidding strategies of GenCo1 in the FTR auction and DA market, respectively for one particular run. The results show that GenCo1 reports *true* or *lower* than true marginal cost of production in 48 out of the 50 runs.

In general, a GenCo with low marginal cost of production will be dispatched before a GenCo with higher marginal cost<sup>14</sup>. Hence, by reporting lower than true marginal cost as the energy supply offer, GenCo1 raises the chance of getting dispatched to provide energy.

Also, 1MW power injection by GenCo1 at bus 1 causes twice as much power flow on transmission line 1 → 3 as compared to 1MW power injection by GenCo2. Hence, GenCo1 causes thermal limit constrained line 1 → 3 to become congested faster than GenCo2.

Finally, given that there is no production capacity limit on either GenCo, the LMPs at their respective buses (if they are dispatched) reflect the marginal costs of production of the last unit of power produced by the GenCos. Hence, a low marginal cost reported by GenCo1 implies lower LMP at its bus compared to what the LMP would be, if the GenCo had reported true marginal cost as its energy supply offer. This implies that the GenCo is willing to take losses from its energy sales. However, low LMP at bus 1 also implies that the LMP differentials are higher, for instance,  $LMP_3 - LMP_1$  increases as  $LMP_1$  decreases. Thus, the payoff from GenCo1's FTR portfolio increases if the LMP differentials increase.

If GenCo1 is able to “create” enough revenues from its FTR portfolio to offset the losses from energy sales, then the logical strategy in FTR auction is to bid high price, in order to secure as many of the desirable FTRs. We can see from Fig. 4.4.3 that GenCo1 ALWAYS selects high action choice in the FTR market. Hence, it can be concluded that GenCo1 is able

<sup>14</sup>In certain cases of grid congestion patterns, low cost GenCo might be able to be dispatched before the higher cost GenCo.

to *learn* to utilize its locational advantage in order to maximize the combined payoffs from the two revenue sources.

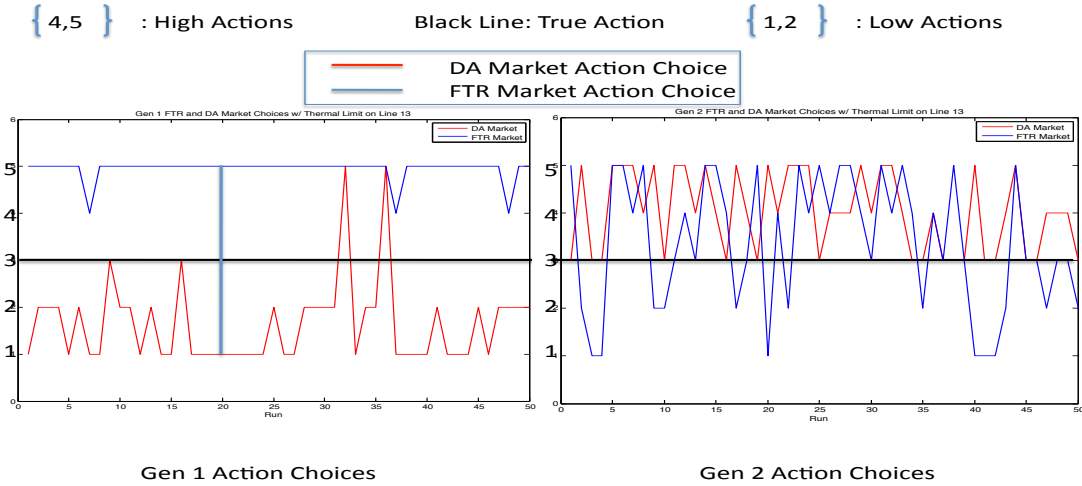

Figure 4.9 GenCo1 and GenCo2 Action Choices when Thermal Limit on line 1  $\rightarrow$  3

GenCo2, on the other hand, does not gain much from reporting low marginal cost as its energy supply offer in the DA market, and its dominant strategy is to report true or higher than true marginal cost of production. Consequently, GenCo2 is not able to create similar LMP differentials due to the higher LMP at bus 2, and so, it does not gain much from a bigger portfolio of FTRs. We can see that GenCo 2 has no clear or dominant strategy to submit demand bids in the FTR auction.

*Case 2: Thermal Limit on Line 1  $\rightarrow$  2*

The action choices of the GenCos in FTR auction and DA market, when thermal limit is imposed on line 1  $\rightarrow$  2, are shown in Fig. 4.4.3. It is clear that both GenCos choose to report *true* or *higher* than true marginal cost of production as their supply offers. Consequently, the LMPs at their respective buses are also high, and hence, the LMP differences are not *high* enough to increase the payoffs from FTR portfolios. We can see that the GenCos have no clear dominant strategy to submit demand bids in FTR auction, as can be seen from the results.

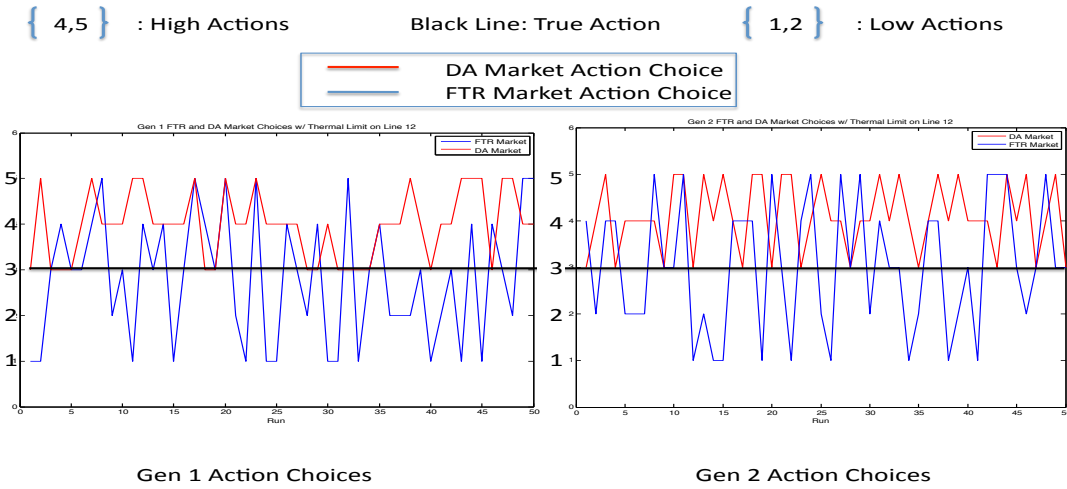

Figure 4.10 GenCo1 and GenCo2 Action Choices when Thermal Limit on line 1  $\rightarrow$  2

## 4.5 Conclusion

By design, the bidding strategies in physical and financial electric power markets are intricately connected. Additionally, the market participants interact with others in either competitive or cooperative manner, in both the markets. The impact of market participants' strategic behavior/interaction can have significant impact on the outcomes of the two markets. In this study, we established a theoretical framework to analyze the bidding strategies of the market participants. We demonstrated the impact of FTR portfolios on the supply offer strategies of market participants in day-ahead markets. In particular, we see that pure strategy Nash-supply function equilibrium exists only for some combinations of FTR portfolios. We then used agent-based model to study the joint bidding strategies of market participants. It was observed that the market participants are able to systematically coordinate their strategies in the two markets. We also see that the location of market participants on the grid, i.e., the proximity to capacity constrained transmission line has a significant impact on their bidding behavior. In some cases the market participants are willing to make losses from the sale of energy in the



day-ahead market, as long as the revenue from FTR portfolio is large enough to compensate for the losses.

## CHAPTER 5. Strategic Wind Trading by Firms with Mixed Portfolio of Generation Assets

The *renewable portfolio standards* (RPS) being enforced in various states and regions within the US have made it imperative for utilities to acquire from 15% to 33% of their energy from renewable resources. Although at present only about 3% of the total electric power produced in the US is from wind, as more US states begin enforcing RPS schemes the bulk of this renewable energy is expected to come from wind. The market rules governing wind power are still evolving, and could lead to profitable opportunities for some firms while disadvantaging others. The resulting market outcomes will depend on the exact nature of rules and the mix of generation assets owned by firms in a region. In this study we will examine the effects of market rules on the trading strategies of profit-seeking firms that supply electric power in wholesale markets using portfolios of generation assets that combine both conventional and wind resources. The findings from this study should generalize to any renewable energy resource for which uncertain generation is a major factor.

### 5.1 Introduction

Ownership structure in an industry can have substantial effects on the overall efficiency of market operations. It has been observed that financial bonding of generation and utility company could reduce a generator's incentive to exercise market power<sup>1</sup>. However, a generation company with units located at different buses of the grid could influence prices (and dispatch quantities) by physical and/or financial withholding of power (Somani and Tesfatsion (2008)). For example, Enron, in 2000, found it profitable to shut down some generation units causing

<sup>1</sup>Vertical integration implies that the company with ownership of both generation and distribution, transacts power at the same price and hence, has no incentive to influence the price outcomes

transmission congestion and higher prices for its other generation sites. The strategic reporting of supply offers led to wild price spikes in the short-term, and eventual break down of the electricity grid. Many lessons from the disastrous chapter have been learned, and regional electricity market monitoring agencies have implemented various market power mitigation policies to keep a strict vigil on the activities of market participants.

Bulk of electricity in US is produced using coal and gas fired power plants. However, given the recent moves towards greater self reliance for energy needs, as well as driven by a need to switch to cleaner renewable generation sources, wind power has gained focus through various political initiatives. However, electric energy production from wind is very uncertain and wind flow prediction remains a very complex problem<sup>2</sup> and hence, wind energy producers are not subject to the strict market rules adhered to by other conventional generation sources. Wind is usually considered as negative load (demand), which reduces the need to dispatch power from other conventional sources. Increased penetration of wind would, presumably, affect the energy and reserve requirements (from conventional generation units) needed to maintain reliable supply of electric power. Hence, as wind penetration increases over the years, so might the uncertainty associated with electric power generation from conventional energy sources. The market rules governing wind energy are still evolving. As will be explained in some detail later, generation companies with diverse portfolio of generation fuel units (i.e., owning both conventional generators and wind farms) could utilize the market rules to maximize their joint profits by reporting supply offers strategically.

To our knowledge, the impact of wind power on market operations while considering the ownership structure of a firm, has not yet been studied. In Wang et al. (2008), Meibom (2007) and Jonsson et al. (2010), the authors analyze the impact of uncertain wind on the electricity market auction mechanism, without any explicitly modeled market structure. In Botterud et al. (2010), the authors present the optimal bidding strategies of wind farmers under different assumptions of risk preferences. However, the model is simplified by assuming that the wind farmers are price takers and also, that they own no other generation sources. In reality, strategic

<sup>2</sup>See ANL ( ) for a comprehensive list of work on wind power forecasting

bidding by wind farms<sup>3</sup> can create price scenarios that either directly increase the wind farm's profits or of the other generation resources owned by the same company.

In this study, we will examine the bidding strategies of horizontally integrated firms that supply electric energy using a portfolio of generation assets. The organization of this chapter is as follows. Section 2 provides an overview of restructured electricity markets, along with the dynamics of the *two-settlement* energy market process. Section 3 provides strategic incentives of mixed generation portfolio companies using data from MISO markets, as well as analytical and simulation models. Section 3 presents a two-bus grid analytical to study optimal bidding strategies of horizontally integrated firms. Section 5 presents results from numerical model where wind plant's optimal supply offer strategy is modeled as a bi-level optimization problem. Section 6 provides general conclusions and proposed future work.

## 5.2 Restructured Electricity Markets – Overview

Electric power industries around the world have undergone restructuring - from government regulated to more market oriented. Restructuring has entailed unbundling of hitherto vertically integrated organizations into independently managed generation, transmission and distribution systems. As a result, electric power markets can be divided into *wholesale* and *retail* layers.

The wholesale power market design proposed by the U.S. Federal Energy Regulatory Commission (FERC) in an April 2003 white paper FERC (2003) encompasses the following core features: central oversight by an *independent system operator* (ISO); a two-settlement system consisting of a day-ahead market supported by a parallel real-time market to ensure continual balancing of supply and demand for power.

We will now describe the day-ahead and real-time energy markets in some detail.

---

<sup>3</sup>Other generation units can engage in strategic bidding also. However, generation capacities and production costs of conventional units are known in advance and hence, can be more closely monitored by market agencies. Wind being an uncertain source of energy can attribute over/under reporting of generation capacity to subjective assessment of wind flow forecasts.

### 5.2.1 Day-Ahead Energy Market

Most conventional generators require advanced notice to start. By operating a financially binding day-ahead market, the ISOs allow generators to receive operating schedules ahead of time, and provides a financial incentive for them to perform as scheduled. Fig. 5.1 shows the timing of daily operations at Midwest ISO (MISO).

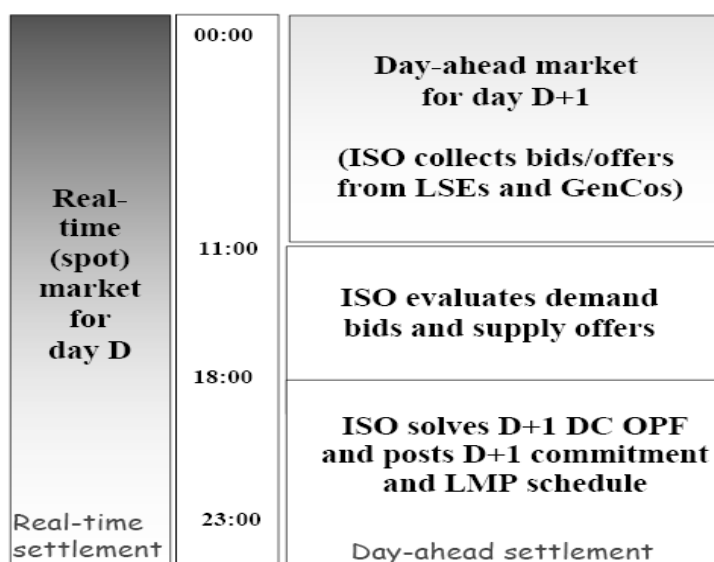

Figure 5.1 ISO activities during a typical day D

Day-ahead energy market is a purely financial market, i.e., no real (physical) injection or withdrawal of electric power takes place. The cleared dispatch quantities and the associated LMPs can be thought of as forward contracts to sell(buy) power, between the ISOs and the generation companies(load serving entities). Like a forward contract in any other commodity, the parties (buyers or sellers) must make whole the contract on the actual trading day (the day after the settlement of day-ahead market) and any shortfalls in generation (or additional load demand) must be accommodated in the real time by the ISO.

### 5.2.2 Real-Time Energy Market

Real-time energy markets are also sometimes referred to as spot-markets and the physical “exchange” of power contracted in the day-ahead market takes place in real-time markets. Because there is always some deviation in real time of actual generation and load from what was scheduled in the day-ahead market, one of the key functions of an ISO is to perform real-time balancing of loads and generation. The ISO performs this through the real-time imbalance energy market, which is the mechanism whereby supply resources are selected to be increased (incremented) or decreased (decremented) in order to maintain system balance. The appropriate awards (penalties) are paid to (paid by) the involved entities that are used in creating system balance.

If there is no change in system condition from the time of day-ahead scheduling to the real-time operations, and the demand and wind conditions are exactly as predicted, then the LMPs in the two markets are exactly equal, i.e., there are no arbitrage opportunities. However, almost always the conditions deviate and often in unexpected ways, like transmission line or generation unit break downs that necessitate bringing up reserve units or other units out of merit-order causing regular price spikes in the real-time. On average however, the day-ahead LMPs observed in reality are higher than the corresponding real-time LMPs, which shows that arbitrage opportunities exist that can be utilized by market participants<sup>4</sup>.

### 5.3 Horizontal Integration and Market Power

In this section <sup>5</sup> we will first present data from Midwest ISO power market that gives an idea of the existing ownership structure in the midwest region. We then used an analytical model provide some intuition for strategic reporting of wind supply offers by firms with mixed generation portfolios. Finally, we use simulation results to show the affects of wind power with-

<sup>4</sup>Many ISO’s now allow *virtual bidding* whereby market participants even with no physical assets can bid to supply or buy power in the day-ahead market, but must close out their positions by buying back (or selling) the same amount in the real-time market. It is argued that virtual bidders should help in drawing down arbitrage opportunities by utilizing any information that might be causing deviation in prices in the day-ahead and real-time markets. However, the virtual markets in most ISO’s (except PJM) are still young and evolving, so the jury is still out.

<sup>5</sup>I would like to express my deepest gratitude to Dr. Huan Zhao who worked very hard to complete this section with me.

olding (in day-ahead market relative to real-time market) on net-earnings of other generation units.

### 5.3.1 Midwest ISO Market Data

We now present some data, reported by Midwest ISO, to give an idea of the industry structure in the midwest region. The facts presented might illustrate how much the industry structure matters in determining the incentives that generation companies might have to act strategically in order to influence market outcomes. The MISO day-ahead cleared supply offer data files show information takes the following tree structure:

Generation Company (Unique ID) → Generation Company. Generation Unit (Unique ID) → Generation Unit. Unit Type (Unit Type ID)

These data show which generation companies were dispatched to produce, using which of their units, where each unit is distinguished by type. From these data one can determine the actual mix of generation fuels used by the generation companies. In addition, one can determine the size of each generation company relative to the market as a whole as measured in terms of total revenues earned.

Table I provides a breakdown of the total energy dispatched in the MISO on November 16, 2010, sorted by unit type. The data are aggregated across all generation companies for all 24 hours. It can be seen that total cleared wind dispatch is second only to total cleared coal dispatch, and similarly for total revenues earned.

Table 5.1 Total Cleared Dispatch by Unit Type for Day-Ahead Market on 11/16/2010

Unit Type	Unit Type Code	Total Energy Dispatch (MWh)	Total Revenue (\$)	% of Total Energy Dispatch	% of Total Revenue
<b>Steam Turbine</b>	<b>4</b>	<b>1,327,256.50</b>	<b>37,278,036.16</b>	<b>92.11</b>	<b>93.51</b>
Comine Cycle ST	5	0	0	0	0
Combustion Turbine	27	9210.30	349988.23	0.64	0.88
Diesel	31	281.00	8705.06	0.02	0.02
Run of River	41	16817.60	411183.43	1.17	1.03
Pumped Storage	42	1200.00	42638.00	0.08	0.11
Combine Cycle CT	51	0	0	0	0
Combine Cycle Aggregate	52	17651.10	542053.74	1.22	1.36
<b>Wind</b>	<b>61</b>	<b>42,271.40</b>	<b>664,749.67</b>	<b>2.93</b>	<b>1.67</b>
Other Fossil	71	25977.30	560628.45	1.80	1.41
Other Peaker	72	0	0	0	0
Demand Response Type 1	87	0	0	0	0
Deman Response Type 2	88	249.00	6978.67	0.02	0.02

In Table II we report cleared coal and wind dispatch amounts, aggregated across all 24 hours of November 16, 2010, for all MISO generation companies that own both coal and wind plants. The coal and wind energy dispatch levels are separately listed for each owner, as identified by MISO owner codes.

Table 5.2 Companies Cleared to Dispatch Both Coal and Wind Energy on 11/16/2010

Owner Code	Wind (MWh)	Coal (MWh)
122062454	480.0	53310.6
122062463	48.0	240.0
122062474	226.0	7735.6
122062486	279.0	8899.6
122062512	1738.0	3651.3
122062517	263.0	26163.0
122062548	0	6151.0
122062550	5231.8	20183.0
122062553	744.0	4550.0
122062561	683.2	15476.5
122062581	512.0	38415.4
122062590	9115.0	85147.8
122062603	836.2	8275.3
122062624	319.0	12278.4
122062627	243.0	0
122062642	2253.0	38385.2
122062646	1109.0	0
122062647	268.0	374.4
122062649	1257.8	29852.6
125767546	1770.0	8459.0
226474818	73.3	150353.6
395307103	1014.0	121690.8
576468110	2211.0	26958.0
576468116	1294.0	21762.6
<b>Total</b>	<b>31968.3</b>	<b>688313.7</b>
<b>Market Total</b>	<b>42271.0</b>	<b>1327300.0</b>
<b>% of Total</b>	<b>75.6%</b>	<b>51.8%</b>

Note that the generation companies that were cleared to produce about 50% of total coal energy for the day were also cleared to produce about 75% of the total wind energy for the same day. This suggests that these companies could have an incentive to report strategic supply offers that take advantage of possible synergies between coal and wind generation.

Interestingly, however, the supply offers for conventional generation units in the MISO are observed to be rather constant over time. Consequently, in this study we will focus on the potential for profitable strategic wind trading by generation companies that own both conventional and wind generation, while the supply offers from conventional generation sources are reported “truthfully”. In particular, we will investigate the potential for wind plants to profitably under/over-report in day-ahead markets, relative to the expected real-time wind



power output. Determining the exercise under/over-reporting by wind plants purely from empirical data is complicated due to the uncertainty of wind generation. The inter- and intra-day variability observed between reported supply offers and actual wind power output could simply be the result of intermittent wind flow.

To get around this problem, we use empirically-grounded analytical and computational models to study the strategic wind-trading opportunities open to mixed-portfolio generation companies. These modeling efforts are described in the following section.

### 5.3.2 Incentives for Strategic Wind Power Supply Offers

The following symbols are used in the model:

Table 5.3 Description of Variables

Variable	Description
$\pi$	Net revenue of the multi-fuel generation company at state 0
$s_{da}^i$	Conventional generator $i$ 's offer in day-ahead
$s_{rt}^i$	Conventional generator $i$ 's offer in real-time
$s_{da}^w$	Wind power's offer in day-ahead
$p_i^d$	Conventional generator $i$ 's cleared dispatch in day-ahead
$p_i^r$	Conventional generator $i$ 's cleared dispatch in real-time
$p_w^r$	Wind power injection in real-time
$lmp_i^d$	Conventional generator $i$ 's cleared price in day-ahead
$lmp_i^r$	Conventional generator $i$ 's cleared price in real-time
$lmp_w^d$	Wind power's cleared price in day-ahead
$lmp_w^r$	Wind power's cleared price in real-time

In this section, we are going to discuss how the wind capacity withholding behavior affects a mixed-portfolio generation company's (MGC) net revenue. This model follows the market rules adopted by Midwest ISO, and focuses on the two-settlement market operation described earlier.

Suppose there are a set of  $N$  buses on the power grid, and there can be more than one generation company selling power to the wholesale market. Starting with the simplest case, we assume that wind bidding is the only variable between day-ahead and real-time market. This assumption also relies on the market rules (and empirical observation) that conventional generation units can not change their real-time supply offers due to economic reasons while wind generation, as an intermittent resource, is taken as is in the real-time. Hence, wind power

could deviate from day-ahead supply offer in real-time market. With this simplification, if the generation company's day-ahead wind supply offer  $s_{da}^w$  equals the real-time wind power injection  $p_w^r$ , the two markets will run under the same conditions. Therefore, day-ahead market cleared LMP at bus  $i$ ,  $lmp_i^d$  is the same as real-time,  $lmp_i^r$ . Similarly, day-ahead market cleared power dispatch  $p_i^d$  is the same as real-time dispatch,  $p_i^r$ . Notice that, we use  $p^i$  to stand for cleared power dispatch at bus  $i$ , and use  $s^i$  to stand for supply offer.

In this market, there exists an MGC  $M$  that has both conventional and wind power generators. Conventional power generator is located at bus  $i$ , where  $i \in M$ , and wind generator is located at bus  $w$ . We assume that company has full information about real-time market wind availability,  $p_w^r$ , i.e., they can make accurate forecast of wind power. The MGC searches for the best wind bidding strategy to maximize the total net earnings  $\pi$ . Suppose that company  $M$  is the only company that strategically reports the wind supply offer, and hence, it is the only resource that deviates in real-time from day-ahead.

For a typical day-ahead operation, generation company makes prediction of  $p_w^r$  for next day's wind power. Following the above discussion, the real-time operation state and system variables are hence determined. Real-time wind power  $p_w^r$  is an exogenous variable. Given  $p_w^r$  and all conventional generators real-time offer  $s_i^r$ , which are same as day-ahead offers, the real-time power dispatch  $p_i^r$  and LMPs  $lmp_i^r$  are determined from real-time DCOPF. Therefore, real-time system variables do not depend on day-ahead wind bidding. Then the net-earning company  $M$  is,

$$\begin{aligned} \pi = & \sum_{i \in M} p_i^d(s_{da}^w) \cdot lmp_i^d(s_{da}^w) + \sum_{i \in M} (p_i^r - p_i^d(s_{da}^w)) \cdot lmp_i^r + \\ & p_w^d \cdot lmp_w^d(s_{da}^w) + (p_{w0}^r - p_w^d) \cdot lmp_w^r - \sum_{i \in M} C(p_i^r) \end{aligned} \quad (5.1)$$

Equation (5.1) shows that the generation company's net earning is a function of its day-ahead wind bidding. Then it will seek for the best wind supply to maximize the net earning.

When we look at the effect of wind bidding on other bus's dispatch, we need to consider the topology of the network. As shown in Zhou et al. (2010), keeping the unit commitment and supply offers unchanged, there exists a linear relationship between system variables and

load perturbation, within a certain system pattern<sup>6</sup>. We first analyze wind bidding behavior at the point where the true expected real-time wind power is bid into the day-ahead market, i.e.,  $s_{da}^w = p_w^r$ . Suppose this point lies inside a certain system pattern, then a small perturbation of wind bidding will not change the determinants of the linear relationship. Denote  $\frac{\partial lmp_i^d}{\partial p_w^d} = \alpha_i$ , and  $\frac{\partial p_i^d}{\partial p_w^d} = \beta_i$ , for all  $i$ , the differential of generation company's total net earning w.r.t. wind supply offer is as follow:

$$\begin{aligned} \frac{\partial \pi}{\partial s_{da}^w} \Big|_{s_{da}^w = p_w^r} &= \sum_{i \in M} \alpha_i \cdot p_i^d + \sum_i \beta_i \cdot (lmp_i^d - lmp_i^r) + \alpha_w \cdot p_w^d + (lmp_w^d - lmp_w^r) \\ &= \sum_{i \in M} \alpha_i \cdot p_i^d + \alpha_w \cdot p_w^d \end{aligned} \quad (5.2)$$

The second equality results from that the fact that in the neighborhood of  $p_w^d = p_w^r$ , day-ahead price will be approximately same as the real-time price. In general,  $\alpha_i < 0$  since more wind production leads to reduction in power produced by generation units with higher production costs, and hence decrease in system price<sup>7</sup>. Suppose that  $\alpha_i < 0$ , then  $\frac{d\pi}{dp_w^d} < 0$ , which means that hybrid GenCo has incentive to bid lower wind power in the day-ahead market.

If generation company deviates from its true expectation of real-time wind availability and withholds wind power in the day-ahead market, it will create positive price difference ( $lmp_i^d - lmp_w^r$ )  $> 0$ , i.e., inter-temporal arbitrage opportunity. Then equation (5.2) becomes:

$$\begin{aligned} \frac{\partial \pi}{\partial s_{da}^w} \Big|_{s_{da}^w < p_w^r} &= \sum_{i \in M} \alpha_i \cdot p_i^d + \sum_{i \in M} \beta_i \cdot (lmp_i^d - lmp_i^r) + \alpha_w \cdot p_w^d - w + (lmp_w^d - lmp_w^r) \\ &= \sum_{i \in M} \alpha_i \cdot p_i^d + \alpha_w \cdot p_w^d + (lmp_w^d - lmp_w^r) + \sum_{i \in M} \beta_i \cdot (lmp_i^d - lmp_i^r) \\ &= \sum_{i \in M} \alpha_i \cdot p_i^d + \alpha_w \cdot p_w^d + \left( \sum_{i \in M} \beta_i \cdot \alpha_i + \alpha_w \right) \cdot \Delta p_w \end{aligned} \quad (5.3)$$

The power injection and withdrawal in the grid must be in balance at all times, so that the extra injection of wind power in real time must be compensated by power reduction by other units, i.e.,  $\sum_{i \in N} \beta_i + 1 = 0$ , where  $N$  is the set of all generators in the grid. With this

<sup>6</sup> A system pattern as defined in Zhou et al. (2010) consists of congested transmission lines and marginal generation units.

<sup>7</sup> There can also be some buses with  $\alpha_i > 0$  due to the network effects.

information it is still hard to sign of the second term of the above equation since it depends on the sensitivity of  $\alpha$ . The hybrid GenCo is best to further lower their wind bid in the day-ahead market until either  $\frac{d\pi}{dp_w^d} = 0$  or until they withhold all their wind capacity, i.e.,  $p_w = 0$ .

From the analysis above, we can see the profitability of strategic wind bidding depends on the network sensitivity. Given that conventional generation units do not change their supply offers, it is the load pattern that determines network sensitivity. As discussed in Zhou et al. (2010), the shadow price  $\sigma_l$  of line capacity is a linear function of load at a give bus. It is also known that location marginal price (LMP) is a function of line capacity shadow price,  $LMP_i = p + \sum_l \tau_{i,l} \cdot \sigma_l$ . Only the congested line  $l$  affects the LMP at bus  $i$ . In peak hours, demand is more likely to create congestion on the grid and cause higher LMP. Therefore load perturbation in the peak hour has a bigger impact on the LMP, and hence GenCo's profit. Given that wind power is generally treated as negative load, similar reasoning can be used to determine the affects of wind power on system LMPs.

### 5.3.3 Net-Earnings of Firms Reporting Wind Supply Offers Strategically

We now show the effects of company  $M$ 's wind bidding strategy of under-reporting supply offers (relative to real-time market) on net-earnings of conventional GenCos in a 5 bus test case. The topology of the network is shown in figure 5.2 above. In addition to the conventional generation resource, we add wind production on bus 5, which replicates the situation that the wind plant is located in a remote area. The penetration of wind power is scaled to 3% of total installed generation capacity, which is as observed in MISO region. Following the analysis of the last section, we test the case that wind farmer withholds ALL the capacity from day-ahead market. The simulation compares the revenues of the 5 conventional generators, with and without wind capacity withholding behavior. The results are listed in Table 5.4 (dollar amount) and Table 5.5 (percentage change). It is noticed that, the impact of withholding is different from generator to generator, and hour to hour. Particularly, it has a bigger impact on GenCo 3 and 5, but very little on GenCo 4. Also, the impact of wind withholding is most significant at hours 17 and 18, which are the peak hours. It is observed that wind withholding could even have negative effect on GenCo 3's net-earnings in hour 18.

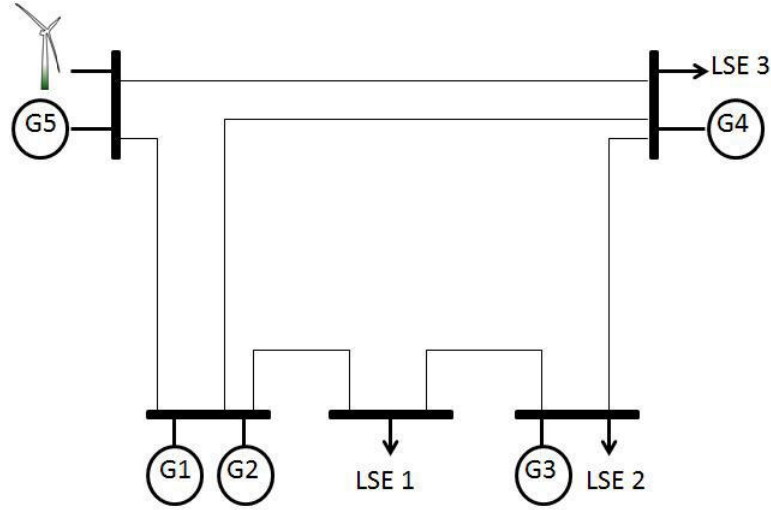

Figure 5.2 5- Bus Grid with Wind Plant

The results provide insight into the incentives of companies with mixed generation portfolios to report their wind supply offers strategically. As shown in section 5.3.1, we see that ownership structure in MISO provides precisely such an incentive to engage in strategic reporting of wind supply offers. In the following section we provide a more rigorous model to study the strategic incentives of an MGC company.

#### 5.4 Two-Bus Grid: Analytical Model of Strategic Wind Trading

To display the wind bidding strategy of a mixed generation profile company (MGC), we will now use the following (Fig. 5.3) a two-bus grid example, where conventional GenCos  $G1$  and  $G2$ , and LSEs  $L1$  and  $L2$  are located buses 1 and 2, respectively. The wind plant  $W$  is located at bus 1 and is owned by the same company (MGC) that operates  $G1$ .

The model setup is as follows:

- Let  $p_{G1}$  and  $p_{G2}$  be the power injected by the two conventional GenCos at their respective

Table 5.4 Extra Net-Earnings from Wind Withholding (dollar)

hour	GenCo 1	GenCo 2	GenCo 3	GenCo 4	GenCo 5	SP Change
0	10.58	1.33	4.94	0.00	40.38	NO
1	9.66	1.18	3.63	0.00	36.38	NO
2	9.32	1.11	3.00	0.00	34.75	NO
3	8.92	1.06	2.59	0.00	33.12	NO
4	5.20	0.61	0.99	0.00	19.16	NO
5	9.57	1.13	2.76	0.00	35.46	NO
6	9.76	1.15	2.98	0.00	36.26	NO
7	11.82	1.43	4.62	0.00	44.35	NO
8	12.05	1.53	6.33	0.00	46.22	NO
9	14.29	1.89	9.64	0.00	55.81	NO
10	14.92	2.00	10.65	0.00	58.54	NO
11	15.00	2.02	10.92	0.00	58.99	NO
12	19.71	2.64	15.46	0.00	77.44	NO
13	18.40	2.44	13.69	0.00	71.96	NO
14	15.72	2.07	10.84	0.00	61.31	NO
15	19.62	2.59	14.39	0.00	76.60	NO
16	16.56	2.23	12.57	0.00	65.17	NO
17	0.90	0.00	(392.21)	1.17	188.36	Yes
18	1.66	0.09	2278.41	0.00	138.42	Yes
19	14.83	2.03	11.46	0.00	58.84	NO
20	13.53	1.85	9.82	0.00	53.51	NO
21	11.64	1.57	7.49	0.00	45.83	NO
22	10.86	1.43	6.16	0.00	42.26	NO
23	10.13	1.30	4.91	0.00	38.91	NO

buses. The quadratic cost functions of the GenCos are:

$$C_1(p_{G1}) = a_1^s \cdot p_{G1} + \frac{1}{2} b_1^s \cdot p_{G1}^2$$

$$C_2(p_{G2}) = a_2^s \cdot p_{G2} + \frac{1}{2} b_2^s \cdot p_{G2}^2$$

where  $a_i^s, b_i^s$  for  $i = 1, 2$  are the true cost function parameters of the GenCos.

- Let  $p_{L1}$  and  $p_{L2}$  be the power withdrawn by the two LSEs at their respective buses. The quadratic benefit functions of the LSEs are:

$$B_1(p_{L1}) = a_1^d \cdot p_{L1} - \frac{1}{2} b_1^d \cdot p_{L1}^2$$

$$B_2(p_{L2}) = a_2^d \cdot p_{L2} - \frac{1}{2} b_2^d \cdot p_{L2}^2$$

where  $a_j^d, b_j^d$  for  $j = 1, 2$  are the true benefit function parameters of the LSEs.

- The wind plant injects power  $p_w^r$  in the real-time markets, while it strategically reports

Table 5.5 Extra Net-Earnings from Wind Withholding (%)

hour	GenCo 1	GenCo 2	GenCo 3	GenCo 4	GenCo 5	SP Change
0	18.47%	648.05%	0.45%	0.00%	3.02%	NO
1	16.77%	525.42%	0.50%	96.60%	2.79%	NO
2	16.18%	498.92%	0.58%	0.00%	2.71%	NO
3	15.44%	449.52%	0.61%	0.00%	2.61%	NO
4	8.48%	126.99%	0.29%	0.00%	1.51%	NO
5	16.77%	578.29%	0.72%	0.00%	2.81%	NO
6	17.13%	609.16%	0.70%	0.00%	2.86%	NO
7	21.35%	1260.87%	0.75%	0.00%	3.45%	NO
8	21.50%	1071.53%	0.51%	0.00%	3.44%	NO
9	26.16%	2231.17%	0.51%	0.00%	4.03%	NO
10	27.52%	2836.38%	0.51%	0.00%	4.20%	NO
11	27.67%	2847.00%	0.50%	0.00%	4.21%	NO
12	39.61%	1000.00%	0.74%	0.00%	5.62%	NO
13	36.23%	97386.57%	0.72%	0.00%	5.26%	NO
14	29.56%	5099.91%	0.60%	0.00%	4.46%	NO
15	39.58%	1000.00%	0.80%	0.00%	5.64%	NO
16	31.40%	7322.44%	0.58%	0.00%	4.67%	NO
17	1000.00%	0.00%	-2.06%	0.83%	10.90%	Yes
18	2.97%	67.54%	84.32%	0.00%	9.62%	Yes
19	27.11%	2292.11%	0.44%	0.00%	4.12%	NO
20	24.21%	1355.98%	0.39%	0.00%	3.75%	NO
21	20.24%	717.38%	0.33%	0.00%	3.23%	NO
22	18.77%	603.85%	0.34%	0.00%	3.04%	NO
23	17.47%	526.13%	0.37%	0.00%	2.87%	NO

supply amount  $p_w^d$  in the day-ahead market. It is assumed that the wind plant can accurately forecast it's real-time power output.

- After receiving GenCo supply offers and LSE demand bids, the ISO solves economic dispatch (ED) problem by maximizing the total net benefit subject to physical network power-flow, and generator capacity constraints. It is assumed that the wind power is used (as bid by wind plant) by ISO before the conventional GenCos because of the near-zero marginal cost of production. ISO's economic dispatch problem can be formulated as follows:

$$\max_{p_{G1}, p_{G2}, p_{L1}, p_{L2}} \sum_{j=1,2} \left( a_j^d \cdot p_{Lj} - \frac{1}{2} b_j^d p_{Lj}^2 \right) - \sum_{i=1,2} \left( a_i^s \cdot p_{Gi} + \frac{1}{2} b_i^s p_{Gi}^2 \right)$$

Subject to:

$$p_{G1} + p_{G2} + p_w = p_{L1} + p_{L2} \quad (5.4)$$

$$-T \leq p_{G1} + p_w - p_{L1} \leq T$$

$$-T \leq p_{G2} - p_{L2} \leq T$$

$$p_{G1} \geq 0, p_{G2} \geq 0, p_{L1} \geq 0, p_{L2} \geq 0$$

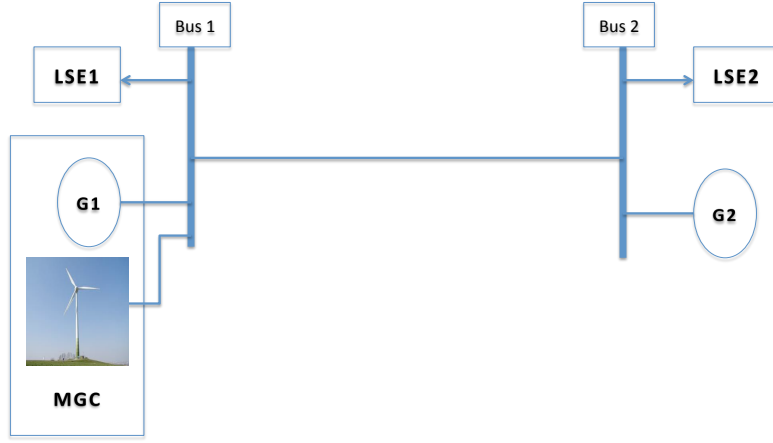

Figure 5.3 Two-bus grid example with mixed generation portfolio company (MGC)

The solution of ISO's problem results in optimal dispatch amounts  $\hat{p}_{G1}(q_w)$  and  $\hat{p}_{G2}(q_w)$  for all GenCos, and LMPs  $\widehat{lm}p_1(p_w)$  and  $\widehat{lm}p_2(p_w)$ .

- It is assumed that the mixed generation portfolio company (MGC) consists of GenCo  $G1$  and the wind plant  $w$ . The MGC submits its wind supply offer in day-ahead market strategically so as to maximize the following profit function:

$$\max_{p_w^d} p_{G1}^d \cdot lmp^d + (p_{G1}^r - p_{G1}^d) \cdot lmp^r + p_w^d \cdot lmp^d + (p_w^r - p_w^d) \cdot lmp^r - C_1(p_{G1}^r)$$

Subject to:

$$p_{G1}^d = \hat{p}_{G1}(p_w^d), \quad p_{G1}^r = \hat{p}_{G1}(p_w^r) \quad (5.5)$$

$$lmp_{G1}^d = \widehat{lm}p_1(p_w^d), \quad lmp_{G1}^r = \widehat{lm}p_1(p_w^r)$$

$$p_w^d \geq 0$$

where  $\hat{p}_{G1}^r$  and  $\widehat{lm}p_{G1}^r$  are optimal dispatch solutions in real-time markets when wind plant produces power at the real-time level of  $p_w^r$ .



### 5.4.1 Analytical Model Results

*Case 1: No capacity limit on transmission line*

In the case of no capacity limit on transmission line connecting the 2 buses, the economic dispatch logic implies dispatching the cheapest generation unit first, up to its capacity limit, to serve the system load. Given the absence of capacity limits, as assumed in this model, the cheapest unit can fulfill the load requirement of the entire system. The same logic also implies that the ISO uses all of the reported wind supply offer first (because of near zero marginal cost of production) to serve as much load as possible. We also assume that the wind capacity in the system is not enough to meet all of load requirement and hence, it is necessary to dispatch conventional units to meet the residual load. The lagrangian function for ISO's economic dispatch problem takes the following form:

$$L = \sum_{j=1,2} \left( a_j^d \cdot p_{Lj} - \frac{1}{2} b_j^d \cdot p_{Lj}^2 \right) - \sum_{i=1,2} \left( a_i^s \cdot p_{Gi} + \frac{1}{2} b_i^s \cdot p_{Gi}^2 \right) + \mu(p_{G1} + p_{G2} + p_w - p_{L1} - p_{L2}) + \lambda_1 p_{G1} + \lambda_2 p_{G2} + \lambda_3 p_{L1} + \lambda_4 p_{L2} \quad (5.6)$$

To simplify the analysis we only consider the case where all dispatch amounts are positive, and hence,  $\lambda_1 = \lambda_2 = \lambda_3 = \lambda_4 = 0$ . The dispatch amount and LMP for GenCo  $G1$  in day-ahead market are:

$$\hat{p}_{G1}^d = \frac{E + F}{G} - \frac{b_1^d D_2 \cdot p_w^d}{G} \quad (5.7)$$

where,

$$\begin{aligned} E &= D_2 B_1 + a_1^d b_2^s B_2, & F &= b_1^d A_2 C_1, & G &= D_1 A_2 + D_2 A_1 \\ A_1 &= b_1^d + b_1^s, & B_1 &= a_1^d - a_1^s, & C_1 &= a_2^s - a_1^s, & D_1 &= b_1^d b_1^s \\ A_2 &= b_2^d + b_2^s, & B_2 &= a_2^d - a_2^s, & C_2 &= a_1^s - a_2^s, & D_2 &= b_2^d b_2^s \end{aligned}$$

The LMP for the system (day-ahead and real-time) takes the following form:

$$lmp_1 = lmp_2 = a_1^s + b_1^s \cdot p_{G1} = a_2^s + b_2^s \cdot p_{G2}$$

Given the dispatch amount and LMP, the MGC reports its wind supply offer to maximize the net-earnings, as shown in Eq. above. The result of this optimization problem is the optimal

day-ahead wind supply offer, which takes the following form:

$$p_w^{d*} = Constant + \frac{p_w^r}{2} \quad (5.8)$$

where,

$$Constant = \frac{b_1^d b_2^d (a_1^s - a_2^s) + b_1^d b_2^s (a_1^s - a_2^d) + b_2^d b_2^s (a_1^s - a_1^d)}{2b_1^s (b_1^d b_2^d + b_1^d b_2^s + b_2^d b_2^s)}$$

To analyze the optimal day-ahead wind supply offer w.r.t the real-time available wind power  $p_w^r$ , we assume that the GenCos have similar cost function parameters, i.e.,  $a_1^s \approx a_2^s$  and  $b_1^s \approx b_2^s$ . Also, it is reasonable to believe that the intercept of load (demand) functions are greater, in magnitude, than the corresponding cost function intercept parameters, i.e.,  $a_1^d \geq a_1^s$  and  $a_2^d \geq a_2^s$ . Under these conditions it is easy to see that  $Constant \leq 0$ . Hence, the optimal wind supply offer strategy of MGC in the day-ahead market is to report less than the real-time available wind power, i.e.,

$$p_w^{d*} < \frac{p_w^r}{2} \quad (5.9)$$

#### Case 2: Capacity limit on transmission line

In the case of a capacity limit of  $T$  MW on transmission line, we can have the following cases optimal dispatch cases: 1)  $\hat{p}_{G1} + p_w - \hat{p}_{L1} \geq T$ , which implies congestion in the direct  $1 \rightarrow 2$ , or 2)  $\hat{p}_{G2} - \hat{p}_{L2} \geq T$ , which implies congestion in the direct  $2 \rightarrow 1$ <sup>8</sup>. We first consider the case when congestion occurs in direction  $1 \rightarrow 2$ . The Lagrangian for ISO's OPF problem takes the following form:

$$\begin{aligned} L = & \sum_{j=1,2} \left( a_j^d \cdot p_{Lj} - \frac{1}{2} b_j^d \cdot p_{Lj}^2 \right) - \sum_{i=1,2} \left( a_i^s \cdot p_{Gi} + \frac{1}{2} b_i^s \cdot p_{Gi}^2 \right) \\ & + \mu (p_{G1} + p_{G2} + p_w - p_{L1} - p_{L2}) + \gamma (T + p_{L1} - p_{G1} - p_w) \\ & + \lambda_1 p_{G1} + \lambda_2 p_{G2} + \lambda_3 p_{L1} + \lambda_4 p_{L2} \end{aligned} \quad (5.10)$$

Once again, solving MGC's net-earnings maximization problem from Eq.. results in the following day-ahead wind supply offer:

$$p_w^{d*} = \frac{p_w^r}{2} - \frac{a_1^d - a_1^s}{2b_1^s} - \frac{b_1^d T}{b_1^s} \quad (5.11)$$

<sup>8</sup>Congestion is the outcome of the OPF problem and hence, it is not technically correct to assume congestion on a transmission a priori. However, the problem may be motivated by assuming that the GenCo is able to accurately *predict* OPF solution, based on supply offer strategies of other GenCos, and hence, can predict congestion on a transmission line. In this paper, we are not interested in modeling the process used by the GenCo to predict congestion.

Using the same reasoning as in the case with no transmission capacity limit, it is reasonable to assume that  $a_1^d \geq a_1^s$ . Hence, once again we see that the optimal wind supply offer in the day-ahead market is to report lower than available real-time wind power, i.e.,

$$\boxed{p_w^{d*} < \frac{p_w^r}{2}} \quad (5.12)$$

When congestion occurs in the opposite direction,  $2 \rightarrow 1$ , the Lagrangian for ISO's OPF problem takes the following form :

$$\begin{aligned} L = & \sum_{j=1,2} \left( b_j^d \cdot p_{Lj} - \frac{1}{2} a_j^d \cdot p_{Lj}^2 \right) - \sum_{i=1,2} \left( b_i^s \cdot p_{Gi} + \frac{1}{2} a_i^s \cdot p_{Gi}^2 \right) \\ & + \mu(p_{G1} + p_{G2} + p_w - p_{L1} - p_{L2}) + \gamma(T + p_{L2} - p_{G1}) \\ & + \lambda_1 p_{G1} + \lambda_2 p_{G2} + \lambda_3 p_{L1} + \lambda_4 p_{L2} \end{aligned} \quad (5.13)$$

Solving the MGC's net-earnings maximization problem results in the optimal wind supply offer of the following form:

$$p_w^{d*} = \frac{p_w^r}{2} + \frac{a_1^s - a_1^d}{2b_1^s} + \frac{b_1^d T}{b_1^s} \quad (5.14)$$

It is interesting to note that the optimal supply offer in this scenario can be *greater* than the real time wind power, i.e.,  $p_w^{d*} \geq p_w^r$ , if the following condition for real-time wind power output were to be true:

$$\boxed{p_w^r \geq \frac{a_1^d - a_1^s}{b_1^s} + T \frac{b_1^d}{b_1^s}} \quad (5.15)$$

In this case, the MGC uses wind power to offset congestion on the transmission line in order to maximize net-earnings from the conventional generation unit. Hence, we see that exist incentives to under/over-report wind supply offers by companies with mixed generation portfolios to maximize their overall net-earnings.

## 5.5 Two-Bus Grid: Numerical Model of Strategic Wind Trading

In this section we present results of strategic wind trading by a mixed-portfolio generation company, obtained from numerical methods. The method allows to extend analysis to grids with more than 2 buses. However, to compare the results with the analytical model, the analysis is done using the same 2-bus grid in Fig. 5.3. We will now briefly describe the numerical method.

### 5.5.1 Mathematical Program with Equilibrium Constraints

Mixed generation company's optimal wind supply offer strategy is modeled as bi-level optimization problem. The inner problem solves ISO's optimal dispatch amounts, given the supply offers and demand bids from GenCos and LSEs, respectively. The MGC then solves for the optimal wind supply offers by maximizing the objective function, given the optimal dispatch values as constraints.

$$\max_{p_w^d} \text{Conventional} + \text{Wind Power Net Earnings}$$

Subject to:

$$\min_{p_{Gi}, PL_j} \text{ISO's SCED Objective}$$

Subject to:

Nodal Power Balance Constraint

Transmission Line Capacity Constraints

Generation Capacity Constraints

Generation Non-negativity Constraints

The inner problem can be represented using FOC from ISO's Lagrangian formulation. The inequality constraints in ISO's optimization problem take the form of complementarity conditions and hence, the outer problem is sometimes referred to as *mathematical problem with complementarity constraints* (MPCC).

### 5.5.2 GenCo's Bi-level Optimization Problem

Wind Farm  $w$  owns conventional GenCo  $i$ . We assume that the conventional GenCos, including the the one owned by the wind farm report their true supply offers. Wind farm can report its supply offer strategically to maximize the following profit function:

$$\begin{aligned} \max_{p_w} & \underbrace{p_{ci}^d \cdot lmp_i^d + (p_{ci}^r - p_{ci}^d) \cdot lmp_i^r}_{\text{Conventional GenCo net-earnings}} - \underbrace{C_i(p_{Gi}^r)}_{\text{Production cost}} \\ & + \underbrace{p_w^d \cdot lmp_i^d + (p_w^r - p_w^d) \cdot lmp_i^r}_{\text{Wind plant net-earning}} \end{aligned} \quad (5.16)$$

The inner level problem is ISO's optimal power flow problem, where the ISO solves for GenCos' optimal dispatch levels and nodal LMPs by taking as given the supply offers of the GenCos, including the wind supply offer.

$$\begin{aligned}
& \min_{p_{cj}, f_{ij}, \theta_j} \sum_{j=1}^J (a_j \cdot p_{cj} + b_j \cdot p_{cj}^2) \\
& \text{subject to:} \\
& p_{cj} - \sum_i f_{ji} + \sum_i f_{ij} = p_{Lj} - p_{wj}, \quad \forall j \in N [lmp_j] \\
& f_{ij} = B_{ij}[\theta_i - \theta_j], \quad \forall ij \in L [\gamma_{ij}] \\
& -f_{ij} \geq -K_{ij}^U, \quad \forall ij \in L [\lambda_{ij}^+] \\
& f_{ij} \geq K_{ij}^L, \quad \forall ij \in L [\lambda_{ij}^-] \\
& -\theta_j \geq -\theta^{Max}, \quad \forall j \in N [\alpha_j^+] \\
& \theta_j \geq -\theta^{Min}, \quad \forall j \in N [\alpha_j^-] \\
& -p_{cj} \geq -p_{cj}^U, \quad \forall j \in N [\mu_j^+] \\
& p_{cj} \geq 0, \quad \forall j \in N [\mu_j^-]
\end{aligned} \tag{5.17}$$

The Lagrangian for ISO's optimal power flow problem is:

$$\begin{aligned}
L = & \sum_{j=1}^J (a_j \cdot p_{cj} + b_j \cdot p_{cj}^2) + lmp_j \left( p_{Lj} + \sum_i f_{ji} - \sum_i f_{ij} - p_{cj} - p_{wj} \right) \\
& \gamma_{ij} (B_{ij}(\theta_i - \theta_j) - f_{ij}) + \lambda_{ij}^+ (-K_{ij}^U + f_{ij}) + \lambda_{ij}^- (K_{ij}^L - f_{ij}) \\
& \alpha_j^+ (-\theta_j^{max} - \theta_j) + \alpha_j^- (\theta_j^{min} - \theta_j) + \mu_j^+ (-p_{cj}^{max} + p_{cj}) + \mu_j^- (p_{cj}^{min} - p_{cj})
\end{aligned} \tag{5.18}$$

The GenCo's MPEC problem can now be written as a *mathematical problem with complementarity constraints* (MPCC), where the objective function is as given in equation (1) subject to

the following constraints:

$$p_{cj} : a_{cj} + 2b_{cj} - lmp_j + \mu_j^+ - \mu_j^- = 0, \quad \forall j \in N \quad (5.19)$$

$$\theta_j : \alpha_j^+ - \alpha_j^- + \sum_{i,ji \in L} B_{ji} \cdot \gamma_{ji} - \sum_{i,ij \in L} B_{ij} \cdot \gamma_{ij} = 0, \quad \forall j \in N \quad (5.20)$$

$$f_{ij} : lmp_i - lmp_j - \gamma_{ij} + \lambda_{ij}^+ - \lambda_{ij}^- = 0, \quad \forall ij \in L \quad (5.21)$$

$$lmp_j : p_{cj} + p_{wj} - \sum_i f_{ji} + \sum_i f_{ij} = p_{Lj}, \quad \forall j \in N \quad (5.22)$$

$$\gamma_{ij} : B_{ij}[\theta_i - \theta_j] - f_{ij} = 0, \quad \forall ij \in L \quad (5.23)$$

$$\alpha_j^+ : 0 \leq \theta_j^{max} - \theta_j \perp \alpha_j^+ \geq 0, \quad \forall j \in N \quad (5.24)$$

$$\alpha_j^- : 0 \leq -\theta_j^{min} + \theta_j \perp \alpha_j^- \geq 0, \quad \forall j \in N \quad (5.25)$$

$$\lambda_j^+ : 0 \leq K_{ij}^U - f_{ij} \perp \lambda_j^+ \geq 0, \quad \forall ij \in L \quad (5.26)$$

$$\lambda_j^- : 0 \leq -K_{ij}^L + f_{ij} \perp \lambda_j^- \geq 0, \quad \forall ij \in L \quad (5.27)$$

$$\mu_j^+ : 0 \leq p_{cj}^U - p_{cj} \perp \mu_j^+ \geq 0, \quad \forall j \in N \quad (5.28)$$

$$\mu_j^- : 0 \leq p_{cj} \perp \mu_j^- \geq 0, \quad \forall j \in N \quad (5.29)$$

The model is being solved using GAMS solvers.

### 5.5.3 Numerical Model Results

The two-bus grid presented in Fig. 5.3 is used to solve the numerical model. The LSEs have fixed demand, and specifically the demand bids ( $p_L$ ) are:

$$p_{L1} = 75 \text{ MW} \ \& \ p_{L2} = 100 \text{ MW}$$

The capacity limit on transmission line  $1 \rightarrow 2$ ,  $T = 20$  MW. The GenCos have the cost function attributes and generation capacity limits as shown in Table. 5.6.

Table 5.6 2-Bud Grid for Numerical Model: GenCo Attributes

GenCo	Ordinate (a)	Slope (b)	Lower Capacity (MW)	Upper Capacity (MW)
G1	3.07	0.5	0	200
G2	2.11	0.3	0	150
Wind	0	0	0	40

As in the analytical mode, it is assumed that MGC can accurately forecast the real-time wind output level  $p_w^x$ , while it may choose to strategically under/over-report the supply offer,

$p_w^d$ , in day-ahead market. The results in Table. 5.7 show the LMPs and power dispatch levels of the GenCos if the MGC reports *true* wind supply offer, i.e.,  $p_w^d = p_w^r$ .

Table 5.7 *True* Wind Supply Offer by Firm with Mixed Portfolio of Generation Assets (MGC)

LMP (\$/MWh)			Dispatch (MWh)		
MGC		GenCo2	MGC		GenCo2
GenCo1	Wind		GenCo1	Wind	
26.11	26.11	30.57	55.00	40.00	80.00

The results in Table. 5.8 show the LMPs and power dispatch levels when the MGC reports wind supply offer in day-ahead market, strategically.

Table 5.8 Strategic Wind Trading by Firm with Mixed Portfolio of Generation Assets (MGC)

LMP (\$/MWh)			Dispatch (MWh)		
MGC		GenCo2	MGC		GenCo2
GenCo1	Wind		GenCo1	Wind	
30.70	30.70	30.70	55.26	24.43	95.30

It is evident that by under-reporting the day-ahead wind supply offer in this case, the MGC is able to drive up the LMPs. The net-earnings for the two cases are shown in Table. 5.9.

Table 5.9 Strategic Wind Trading by Firm with Mixed Portfolio of Generation Assets (MGC)

Net-Earnings (\$)	
<i>True</i> Supply Offer	Strategic Supply Offer
1650.35	1920.06

Hence, by under-reporting the MGC is able to secure extra net-earnings from its mix of generation assets. It is noteworthy, that the revenue from wind plant, by itself, decreases, but the additional net-earnings from the conventional unit offset the reduction in reduction wind plant revenues.

## 5.6 Conclusion

The analytical and computational work presented in sections 3, 4 and 5 illustrates the incentives of wind power producers to report wind supply offers. It is observed that mixed-

portfolio generation companies can either under-report wind supply offers to either increase LMPs at the sites of their conventional generation units, or over-report to offset transmission congestion. The next step is to extend the numerical model over a larger grid. This would allow us to study the affects of spatial location of wind plants, as well as, model more complex ownership structures.

The study was conducted in the absence of any uncertainty in wind power production. Future studies would include strategic decision of profit-seeking companies, with different risk preferences, when wind flow and/or energy demand are stochastic. For example, we can study how mixed generation portfolio companies determine the optimal supply offers for their conventional and wind generation, based on risk valuation measures such as Value-at-Risk (VaR) and Conditional Value-at-Risk (CVaR); see, for example, the analysis in [10].

This work should help electric power market participants to understand the value of information when there exists uncertainty about wind availability and demand levels. It should also help policy makers to efficiently incorporate greater amount wind energy and demand response programs into current power systems by better understanding the behavior of market participants.



## CHAPTER 6. General Conclusions

Electric power industries around the world have undergone restructuring - from government regulated to more market oriented. However, electric power is not a tradeable asset in the classical sense since storage costs are prohibitively high. This is a very fundamental factor distinguishing electric power markets from other markets. Additionally, the recent moves towards greater self reliance for energy needs, as well as driven by a need to switch to cleaner renewable generation sources, wind power has gained focus through various political initiatives. Hence, the study of electric power as an economics commodity presents special challenges.

In this thesis, we investigate the risk management issues of market participants and overall market efficiency at the wholesale power markets (individual and market operators). We also study how the market rules dealing with renewable energy sources affect market participants' strategic trading behaviors.

In chapter 2, we presented the difficulties in objectively measuring market participants' abilities to exercise market power owing to the physical characteristics of electricity. Using a wholesale power market test-bed (AMES), we studied the efficacy of various traditional, as well as newly proposed, measures of market performance, in a dynamic setting with learning agents. It is observed that Lerner Index (LI) and Market Advantage Index (MAI) correctly indicate diminishing ability to exercise market power by market participants, as the level of price sensitivity increases. On the other hand, Herfindahl-Hirschman Index (HHI) can be misleading, indicating the potential to exercise market power, when no potential exists. Similarly, Residual Supply Index (RSI) can be misleading, indicating *no* potential to exercise market power, when such potential does exist, as indicated by positive values of LI and MAI.

In chapter 3, we introduced the concept of *price risk* in restructured power markets. We presented a brief scenario illustrating the origin of price risk and the various measures market

participants employ to hedge against those risks. We then provided the definition of Financial Transmission Rights (FTR), and how FTRs can be used along with *bilateral contracts* to hedge against price risk. The chapter also presented a survey of research on implications of FTR market design on overall wholesale power market efficiency.

In chapter 4, we presented a study of joint bidding strategies of market participants in inter-linked financial and physical energy markets. Specifically, we study how generation companies bid into ISO organized FTR auctions based on their expectations of payoffs in the day-ahead energy markets, and the subsequent supply offer strategy in the day-ahead market to maximize joint net-earnings from energy sales and revenues from the FTRs already acquired. The results show that Nash-supply function equilibria exist only for certain portfolios of FTRs. It is also observed that the strategic behavior of generation units changes dramatically for different congestion patterns in the grid. However, even for a simple setup with two identical generators, it is not easy to solve the problem using purely analytical methods. Hence, we then used agent-based computational methods to solve for the joint decision making problem. Generation companies (GenCos) were modeled as adaptive learners in both the markets, interacting repeatedly with other GenCos until they converged to “stable” action choices in the two markets. The results show that the GenCos are able to learn optimal strategies, based on spatial location on the grid. Additionally, the GenCos can systematically coordinate their strategies in the two markets.

In chapter 5 we presented the strategic incentives of companies with both conventional units and wind plants, to under/over-report wind supply offers in day-ahead markets, relative to the expected wind power output in real-times markets. We provided empirical basis for such a study, by using data from Midwest ISO (MISO) markets. The use of analytical models and numerical methods demonstrates the strategic incentives of mixed generation portfolio companies (MGC). It is observed, using a 2-bus grid, that MGCs can have incentives to both under and over-report wind supply offers in day-ahead markets depending on the location of generation assets, as well as, the congestion patterns.

## APPENDIX A. Optimal Power Flow Calculation

### Load-Demand Conditions for Production Decisions

The following grid, Figure. A.1, has GenCos B and S at busses 1 and 2 respectively, while the LSE is located at bus 3. GenCo B produces at marginal cost,  $MC_B = 10 + 0.01p_{GB}$  where the avoidable fixed cost is  $10\$/MW$  and  $p_B$  is MW amount of electricity produced. Similarly, GenCo S produces at marginal cost,  $MC_S = 13 + 0.02p_{GS}$ . The LSE at bus 3 demands fixed load  $p_L$  MW. It is assumed that the total installed generation capacity at each bus exceeds the

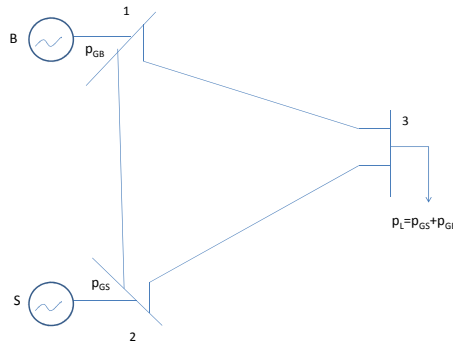

Figure A.1 Three Node Grid

load demand at any given time. It is also assumed that the GenCos report their true marginal costs in energy supply offers to the ISO power pool auction. Analytical solutions for the power pool trading can be characterized for scenarios with or without congestion in the grid. First, we will find the load demand conditions under which either/both GenCos are dispatched to produce electricity in a grid with no binding transmission constraints. The following conditions must satisfy for the case with no congestion in the grid:

- The total electricity generation at the two buses must equal the total load demand at bus 3, i.e.

$$p_{GS} + p_{GB} = p_L \quad (\text{A.1})$$

- Energy price is same across the nodes and equals the marginal cost of producing the last unit of electricity (LMP) at two production busses.

$$\begin{aligned} \Pi &= MC_B = MC_S \\ \Pi &= 10 + 0.01p_{GB} = 13 + 0.02p_{GS} \end{aligned} \quad (\text{A.2})$$

where  $\Pi$  is the energy price and because there is no congestion in the grid, the LMPs for buses 1 and 2 are equal, i.e.  $\Pi_B = \Pi_S = \Pi$ .

*Case 1:* Only ONE GenCo is producing because the load is not high enough to induce production from both GenCos. It is immediately apparent that GenCo B is the only one producing electricity because of the lower marginal cost of production. The upper limit of load demand level for the condition to hold is the following:

$$\begin{aligned} MC_B &\leq MC_S \\ 10 + 0.01p_L &\leq 13 \end{aligned} \quad (\text{A.3})$$

Hence, for load demand conditions such that  $p_L \leq 300$  MW, only GenCo B serves the load.

*Case 2:* Both GenCos are dispatched to serve the load  $p_L > 300$  MW. Conditions in equations 2-3 above are still satisfied and by simultaneously solving the two equation, following dispatch levels are observed at the two production busses.

- *GenCo B:*  $p_{GB} = 100 + 2/3p_L$  MW
- *GenCo S:*  $p_{GS} = 1/3p_L - 100$  MW

The energy price (LMPs) across the busses is  $\Pi = 11 + .02/3p_L$  \$/MW.

## Branch Power Flow Solutions

In this subsection we will derive branch flows through individual transmission lines using the power flow solutions obtained above. The power flows are derived first for the case without-, and then extended to the case with binding transmission line constraints. It is assumed that the reactance on each transmission line is the same and specifically,  $x_{12} = x_{23} = x_{13} = .2$ . It is also assumed that  $p_L > 300$  MW so that both GenCos are in operation. The following set of load-balance and power flow rules are used to obtain individual branch power flows.

$$p_{GB} + p_{GS} = p_L \quad (\text{A.4})$$

$$p_{GB} = P_{13} + P_{12} \quad (\text{A.5})$$

$$p_{GS} = P_{21} + P_{23} \quad (\text{A.6})$$

$$p_L = P_{13} + P_{23} \quad (\text{A.7})$$

where equation (58) represents load-balance condition and equations (59)-(61) represent branch flows constituting energy injection/withdrawal conditions.

*Case1: No Transmission Line Limits Imposed.* As shown in Figure. A.2 below, the method of superposition Kirschen and Strbac (2005) can be used to identify branch flows in the grid owing to power injections at various busses. Hence, the following conditions for branch flows must hold,

$$\begin{aligned} P_{13} &= P_{213}^S + P_{13}^B \\ P_{12} &= P_{123}^B + (-P_{213}^S) = -P_{21} \\ P_{23} &= P_{23}^S + P_{123}^B \end{aligned} \quad (\text{A.8})$$

The set of equations show that power flows through transmission lines are comprised of flows owing to injections at different buses. Again, using the methods in Kirschen and Strbac (2005) the following formula can be used to obtain branch flow due to power injection at a specific bus.

$$P_{km} = PTDF_{km}^i * p_{Gi} \quad (\text{A.9})$$

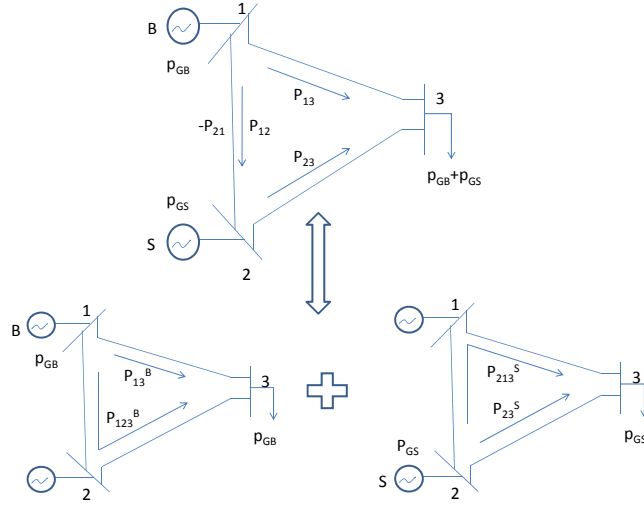

Figure A.2 Branch flows via superposition WITH NO transmission constraints

for all transmission lines  $km \in BR$  and all GenCos  $i = 1 \dots I$ , where  $PTDF_{km}^i$  is the *Power Transmission Distribution Factor* and describes the amount power transmitted through branch  $km$  due to 1 MW injection of power by GenCo  $i$  at bus  $k$  and to be withdrawn at bus  $m$ . The PTDF for a transmission line is calculated as follows:

$$PTDF_{km}^i = \frac{\sum_{n=1, n \neq k}^K x_n}{\sum_{m=1}^K x_m}. \quad (\text{A.10})$$

Hence, the power flow on transmission line  $1 \rightarrow 3$  due to power injected at bus B is,

$$P_{13}^B = PTDF_{13}^B * p_{GB} = \left( \frac{.2 + .2}{.6} \right) * p_{GB} = \frac{2}{3} p_{GB} \quad (\text{A.11})$$

Similarly, the power flow on branch  $2 \rightarrow 1 \rightarrow 3$  due to power injected at node S is,

$$P_{213}^S = PTDF_{213}^S * p_{GS} = \left( \frac{.2}{.6} \right) * p_{GS} = \frac{1}{3} p_{GS} \quad (\text{A.12})$$

Hence, the total power flow on line  $1 \rightarrow 3$  is given by,

$$P_{13} = P_{13}^B + P_{213}^S = \frac{2}{3} p_{GB} + \frac{1}{3} p_{GS} = \frac{100}{3} + \frac{5}{9} p_L \quad (\text{A.13})$$

Similarly, the power flows on lines  $2 \rightarrow 3$  and  $1 \rightarrow 2$  are,

$$\begin{aligned} P_{23} &= \frac{4}{9} p_L - \frac{100}{3} \\ P_{12} &= \frac{200}{3} + \frac{1}{9} p_L \end{aligned} \quad (\text{A.14})$$

The energy dispatch levels and LMPs at various buses are the same as found above for the unconstrained transmission lines case.

*Case 2: Transmission Line Constraint Imposed.* Now lets assume there exists a transmission line limit on line  $1 \rightarrow 3$ ,  $P_{13}^U$ , and the corresponding load demand at bus 3 is  $\widehat{p}_L > 300$  MW such that,

$$P_{13} = P_{13}^U = \frac{100}{3} + \frac{5}{9}\widehat{p}_L. \quad (\text{A.15})$$

In case the load at bus 3,  $p_L > \widehat{p}_L$ , i.e. load demand exceeds the critical limit after which line  $1 \rightarrow 3$  becomes congested so that  $P_{13} > P_{13}^U$  and power equivalent to  $P_{13} - P_{13}^U = \frac{5}{9}(p_L - \widehat{p}_L)$  must be transmitted in the direction  $3 \rightarrow 1$  to decongest the line. The required transmission flows can be achieved by injecting appropriate amount of power at bus 2 and withdrawing the same at bus 1. Using the branch power flow rule in equation (63), we know that for 1 MW of power injected at bus 2 and withdrawn at bus 1,  $1/3$  MW flows through branch  $2 \rightarrow 3 \rightarrow 1$  and  $2/3$  MW flows through branch  $2 \rightarrow 1$ . Figure. A.3 shows the branch flows.

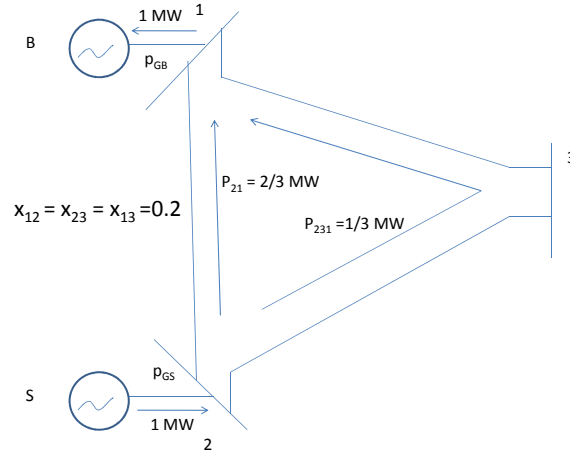

Figure A.3 Branch flows for ONE MW power injection at Bus 2 and withdrawn at bus 1

The required power of  $F$  MW to be injected at bus 2 must satisfy  $P * \frac{1}{3} = \frac{5}{9}(p_L - \widehat{p}_L)$ . Hence,

$P = \frac{5}{3}(p_L - \widehat{p}_L)$  and the implied branch flows are

$$\begin{aligned} P_{21}^S &= \frac{10}{9}(p_L - \widehat{p}_L) \\ P_{231}^S &= \frac{5}{9}(p_L - \widehat{p}_L) \end{aligned} \quad (\text{A.16})$$

Using the method of superposition as shown in Figure. A.4 we can obtain the required branch power flows satisfying the transmission line constraints. The superposition method combines original power flow solutions from the unconstrained case (eqns 14-15) with the implied power flows due to additional  $F$  MW of power injected at bus 2 (to induce offsetting power transmission on line  $3 \rightarrow 1$  to decongest) to result in power flows through branches that comply with transmission line constraints.

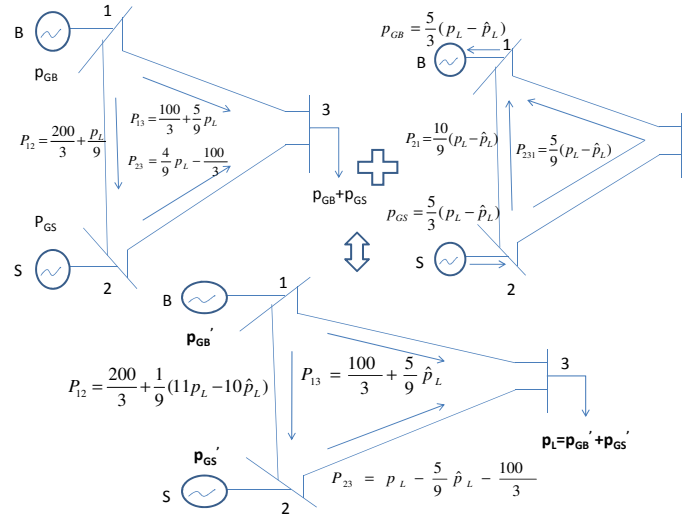

Figure A.4 Branch flows via superposition WITH transmission constraints

The branch flows are as follows,

$$\begin{aligned} P'_{13} &= \frac{100}{3} + \frac{5}{9}\widehat{p}_L \\ P'_{23} &= p_L - \frac{5}{9}\widehat{p}_L - \frac{100}{3} \\ P'_{12} &= \frac{200}{3} + \frac{10}{9}\widehat{p}_L - L \end{aligned} \quad (\text{A.17})$$



The power dispatch levels of GenCos at the two production busses are the following,

$$\begin{aligned} P'_{GS} &= p_{GS} + \frac{5}{3}(p_L - \widehat{p}_L) = 2p_L - \frac{5}{3}\widehat{p}_L - 100 \\ P'_{GB} &= p_{GB} - \frac{5}{3}(p_L - \widehat{p}_L) = 100 + \frac{5}{3}\widehat{p}_L - p_L \end{aligned} \quad (\text{A.18})$$

The LMPs at the two production busses are the following,

$$\begin{aligned} LMP'_1 &= \Pi_B = 10 + 0.01p'_{GB} = 11 + 0.01 \left( \frac{5}{3}\widehat{p}_L - p_L \right) \\ LMP'_2 &= \Pi_S = 13 + 0.02p'_{GS} = 11 + 0.02 \left( 2p_L - \frac{5}{3}\widehat{p}_L \right) \end{aligned} \quad (\text{A.19})$$

It is easy to verify that in case no transmission constraints are binding and hence, no transmission congestion, the results for branch power flows, energy dispatch quantities of GenCos and the LMPs across the grid are the same as obtained for the no-transmission-constraints case. The result is proved by replacing  $\widehat{p}_L$  with  $p_L$  in all the expressions.

## BIBLIOGRAPHY

The ames wholesale power market test bed.

Wind power forecasting: State-of-the-art 2009. *Department of Information Sciences, Argonne National Lab*, <http://www.dis.anl.gov/pubs/65613.pdf>.

Babayigit, C., Rocha, P., and Das, T. K. (2010). A two-tier matrix game approach for obtaining joint bidding strategies in ftr and energy markets. *IEEE Transactions On Power Systems*, 25(3):1211 – 1219.

Baldick, R. and Hogan, W. (2002). Capacity constrained supply function equilibrium models of electricity markets: Stability, non-decreasing constraints, and function space iterations. *Working Paper Series, Program on Workable Energy Regulation (POWER), University of California Energy Institute*,.

Barlow, M. (2002). A diffusion model for electricity prices. *Mathematical Finance*, 12(4):287–298.

Bautista, G., Quintana, V. H., and Aguado, J. A. (2004). Interaction of market power and financial transmission rights in power networks. *Proceedings Canada Conference Electrical and Computer Engineering*, 2:1067–1072.

Benjamin, R. (2010). A further inquiry into ftr properties. Technical report, Round Table Group, Inc.

Bessembinder, H. and Lemmon, M. (2002). Equilibrium pricing and optimal hedging in electricity forward markets. *Journal of Finance*, 57:1347–1382.

- Borenstein, S., Bushnell, J., and Knittel, C. R. (1999). Market power in electricity markets: Beyond concentration measures. *The Energy Journal*, 20(4):65–88.
- Botterud, A., Wang, J., Bessa, R., Keko, H., and Miranda, V. (2010). Risk management and optimal bidding for a wind power producer. *Proceeding of the IEEE Power and Energy Society General Meeting*. Minneapolis, MN.
- Bushnell, J. (1999). Transmission rights and market power. *The Electricity Journal*, 12(8):77–85.
- CAISO (2009). Market issues and performance, 2008 annual report. Technical report. Department of Market Monitoring, California Independent System Operator Corporation. [www.caiso.com/2390/239087966e450.pdf](http://www.caiso.com/2390/239087966e450.pdf).
- Cartea, A. and Figueroa, M. (2005). Pricing in electricity markets: a mean reverting jump diffusion model with seasonality. *Applied Mathematical Finance*, 12(4):313–335.
- Chen, L., H. Suzuki, T., and Shimura, Y. (2002). Components of nodal prices for electric power systems. *IEEE Transactions on Power Systems*, 17(1):41–49.
- Cheng, X. and Overbye, T. J. (2006). An energy reference bus independent LMP decomposition algorithm. *IEEE Transactions on Power Systems*, 21(3):1041–1049.
- Conejo, A. J., Castillo, E., Minguez, R., , and Milano, F. (2005). Locational marginal price sensitivities. *IEEE Transactions on Power Systems*, 20(4):2026–2033.
- Cramton, P., Chao, H.-P., and Wilson, R. (2005). Review of the proposed reserve markets in new england. Technical report, Market Design, Inc. [www.cramton.umd.edu/papers2005-2009/cramton-chao-wilson-review-of-proposed-reserve-markets.pdf](http://www.cramton.umd.edu/papers2005-2009/cramton-chao-wilson-review-of-proposed-reserve-markets.pdf).
- Deng, S.-J., Oren, S., and Meliopoulos, S. (2005). The inherent inefficiency of simultaneously feasible financial transmission rights auctions. Working paper.
- Eydeland, A. and Geman, H. (1998). Pricing power derivatives. *Risk*, 11:71–73.
- FERC (2003). Notice of White Paper.

- Finney, J. D., Othman, H. A., and Rutz, W. L. (1997). Evaluating transmission congestion constraints in system planning. *IEEE Transactions on Power Systems*, 12(3):1143–1150.
- Geman, H. and Roncoroni, A. (2006). Understanding the fine structure of electricity prices. *Journal of Business*, 79(3).
- Hogan, W. (1992a). Contract networks for electric power transmission. *Journal of Regulatory Economics*, 4:211–242.
- Hogan, W. W. . (1992b). Contract networks for electric power transmission. *Journal of Regulatory Economics*, 4:211–242.
- Hogan, W. W. (2000). Market power in theory and practice, comments on joskow and tirole(2000) and johnsen, verma and wolfram(1999). *Power Conference*.
- ISO-NE (2008). Homepage, ISO new england, inc. Technical report. [www.iso-ne.com](http://www.iso-ne.com).
- ISO-NE (2009). 2008 annual markets report in iso new england. Technical report. Independent Market Monitoring Unit, ISO New England, Inc. [www.iso-ne.com/markets/mktmonmit/rpts/other/amr08\\_final\\_061709.pdf](http://www.iso-ne.com/markets/mktmonmit/rpts/other/amr08_final_061709.pdf).
- Jonsson, T., Pinson, P., and Madsen, H. (2010). On the market impact of wind energy forecasts. *Energy Economics*, 32(2):313–320.
- Joskow, P. (2006). Markets for power in the united states: An interim assessment. *The Energy Journal*, 27(1):1–36.
- Joskow, P. and Tirole, J. (2000). Transmission rights and market power on electric power networks. *RAND Journal of Economics*, 31(3):450–487.
- Kirschen, D. S. and Strbac, G. (2005). *Power System Economics*. Wiley, Hoboken, NJ.
- Lally, J. (2002). *Financial transmission rights: Auction example*. ISO New England, Inc.
- Li, H., Sun, J., and Tesfatsion, L. (2008a). Dynamic Imp reponse under alternative price-cap and price-sensitive demand scenarios. *Proceedings, IEEE Power and Energy Society General Meeting, Pittsburgh, PA,*

- Li, H., Sun, J., and Tesfatsion, L. (2008b). Separation and volatility of locational marginal prices in restructured wholesale power markets. *Working Paper, Economics Department, Iowa State University, Ames, IA*.
- Li, H. and Tesfatsion, L. (2010). Iso net surplus collection and allocation in wholesale power markets under locational marginal pricing. *ISU Economics Working Paper No. 09015*. [www.econ.iastate.edu/tesfatsi/ISONetSurplus.WP09015.pdf](http://www.econ.iastate.edu/tesfatsi/ISONetSurplus.WP09015.pdf).
- Litvinov, E., Zheng, T., Rosenwalk, G., and Shamsollahi, P. (2004). Marginal loss modelling in Imp calculation. *IEEE Transactions on Power Systems*, 19(2):880–888.
- Liu, H., Tesfatsion, L., and Chowdhury, A. A. (2009). Derivation of locational marginal prices for restructured wholesale power markets. *Journal of Energy Markets*, 2(1):3.
- Liu, Y. and Wu, F. F. (2007). Impacts of network constraints on electricity market equilibrium. *IEEE Transactions On Power Systems*, 22(1):126–134.
- Longstaff, F. and Wang, A. (2004). Electricity forward prices: a high-frequency empirical analysis. *Journal of Finance*, 59(4):1877–1900.
- Lucia, J. and Schwartz, E. (2002). Electricity prices and power derivatives: evidence from the nordic power exchange. *Review of Derivatives Research*, 5(1):5–50.
- Mani, S. and Ainspan, A. (2005). Demand response as a tool to alleviate market power. *Proceedings, 24th Annual Conference of the USAEE/IAEE, Washington, D.C.*, pages 8–10.
- Meibom, P. (2007). Market consequences of large-scale penetration of wind. *IEEE Power and Energy Magazine*.
- MISO. Bpm 003 - Energy Markets Instruments. Technical report. [www.misoenergy.org](http://www.misoenergy.org).
- MISO (2008). Online. Homepage, Midwest ISO, Inc.
- MISO (2009). 2008 state of the market report for the midwest iso. Technical report. Potomac Economics, Independent Market Monitor for the Midwest ISO. [www.midwestiso.org/publish/Document](http://www.midwestiso.org/publish/Document).

- Nicolaisen, J., Petrov, V., and Tesfatsion, L. (2001). Market power and efficiency in a computational electricity market with discriminatory double-auction pricing. *IEEE Transactions on Evolutionary Computation*, 5(5):504–523.
- Oren, S. (1997). Economic inefficiency of passive transmission rights in congested electricity systems with competitive generation. *The Energy Journal*, 18(1):63–83.
- Pepall, L., Richards, D. J., and Norman, G. (1999). *Industrial Organization Theory: Contemporary Theory and Practice*. South-Western Collge Publishing, Cincinnati, OH.
- PJM (2009). 2008 state of the market report. Technical report. Vol. 2 Detailed Analysis, Monitoring Analytics, LLC, Independent Market Monitor for PJM. [www.monitoringanalytics.com/reports/PJM\\_State\\_of\\_the\\_Market/2008/2008\\_som-pjm\\_volume2.pdf](http://www.monitoringanalytics.com/reports/PJM_State_of_the_Market/2008/2008_som-pjm_volume2.pdf).
- Sarkar, V. and Khaparde, S. A. (2008). A comprehensive assessment of the evolution of financial transmission rights. *IEEE Transactions On Power Systems*, 23(4):1783–1795.
- Schwartz, E. (1997). The stochastic behaviour of commodity prices: implications for valuation and hedging. *Journal of Finance*, LII(3):923–973.
- Shahidehpour, M., Yamin, H., and Li, Z. (2002). *Market Operations in Electric Power Systems*. IEEE/Wiley-Interscience, John Wiley & Sons, Inc.
- Sheffrin, A. Y., Chen, J., and Hobbs, B. (2004). Watching watts to prevent abuse of power. *IEEE Power and Energy Magazine*, pages 58–65.
- Siddiqui, A., Bartholomew, E., Marnay, C., and Oren, S. (2003). On the efficiency of the new york independent system operator market for transmission congestion contracts.
- Somani, A. and Tesfatsion, L. (2008). An agent-based test bed study of wholesale power market performance measures. *IEEE Computational Intelligence Magazine*, 3(4):56–72.
- Stoft, S. (1999). Financial transmission rights meet cournot: How {TCC}s curb market power. *The Energy Journal*, 20(1):1–4.

- Stoft, S. (2002). Power system economics: Designing markets for electricity. *Wiley-Interscience, IEEE Press, New York, NY.*
- Sun, J. (2005). *U.S. Financial Transmission Rights: Theory and Practice*. Phd thesis, Iowa State University.
- Sun, J. and Tesfatsion, L. (2007a). DC optimal power flow formulation and solution using QuadProgJ. *Proceedings, IEEE Power and Energy Society General Meeting, Tampa, Florida.*  
[www.econ.iastate.edu/tesfatsi/DC-OPF.JSLT.pdf](http://www.econ.iastate.edu/tesfatsi/DC-OPF.JSLT.pdf).
- Sun, J. and Tesfatsion, L. (2007b). Dynamic testing of wholesale power market designs: An open-source agent-based framework. *Computational Economics*, 30(3):291–327.
- Twomey, P., Green, R., Neuhoff, K., and Newbery, D. (2005). A review of the monitoring of market power: Possible roles of tsos in monitoring for market power issues in congested transmission systems. *05-002 WP, Center for Energy and Environmental Policy Research*.
- Wang, J., Shahidehpour, M., and Li, Z. (2008). Security-constrained unit commitment with volatile wind power generation. *IEEE Transactions on Power Systems*, 23(3):1319–1327.
- Wu, T., Alaywan, Z., and Papalexopoulos, A. D. (2005). Locational marginal price calculations using the distributed-slack power-flow formulation. *IEEE Transactions on Power Systems*, 20(2):1188–1190.
- Yu, N., Somani, A., and Tesfatsion, L. (2010). Financial risk management in restructured wholesale power markets: Concepts and tools. *IEEE Power Engineering Society General Meeting*.
- Zhou, Q., Tesfatsion, L., and Liu, C. (2010). Short-term congestion forecasting in wholesale power markets. *Working Paper No.10025, Economics Department, Iowa State University*.